

ZHEJIANG AOMA ELEVATOR CO.,LTD.

Addr: No. 6666, Qianghua Road, Nanxun Economic
Development Zone, Huzhou City, Zhejiang Province, China
Tel: +86-0572-3636576
E-mail: cyma@vksfujilift.com
Http://www.vksfujilift.com





Scan into the official website

The printed products are for reference only; the company has the right to change the designs and specifications of the products at any time. The information contained in the printed products does not constitute any express or implied guarantees or commitments for the products and its applicability, merchantability, and quality of special purposes, or any terms of procurement agreement.

2023 version



- | | |
|---|---|
|  Passenger elevator |  Car elevator |
|  Observation elevator |  Hospital elevator |
|  Escalator |  Dumbwaiter |
|  Moving walk |  Stair elevator |
|  Shopping cart escalator |  Lifting platform |
|  Freight elevator | |



Company introduction



Zhejiang Aoma Elevator Co., Ltd. is located in Nanxun, Huzhou, Zhejiang, China. Nanxun is a veritable smart elevator town. The smart town takes the entire elevator manufacturing as its core, integrates leading elevator parts companies, introduces high-end technical talents, realizes technological innovation and builds China's leading elevator characteristic industry. The characteristic towns are small and beautiful, with exquisite features. Our products include: passenger elevators, home elevators, sightseeing elevators, moving walk, escalators, car elevators, hospital elevators, shopping cart escalators, as well as other types of elevators and various elevator accessories, providing you with select. We always adhere to the height of the international elevator industry, introduce advanced equipment at home and abroad, strive to improve production efficiency and product quality and only provide you with better and safer elevator products.

Our company always puts customers first. Before placing an order, we will customize the elevator for you according to the different requirements of the customer, such as the specific specifications of the elevator shaft, the height of the floor, the design of the machine room and the size and height of the elevator. Elevator car... We know that each customer has different requirements for elevators, which is why customization is our top priority. Another feature we are proud of is that we provide customers with free elevator civil drawings before placing orders, customize products according to customers' requirements, and attach a complete English assembly instruction manual to the final delivery for customers understand that our custom products work without difficulty.

Comfortable travel transport

specialist in vertical space

In order to meet the different needs of global users for elevators and adhere to the height of the international elevator industry, we implement very strict industry standards. High strength hall door, anti pickling door device, speed limiter, safety gear and other safety protection devices, real-time monitoring, to ensure the safety of passengers using the ladder.

VVVF inverter control integrated controllerr

Integrated controller is an intelligent control system which integrates computer technology, automatic control technology, network communication technology and motor vector drive technology. It has international advanced level.

Prevent the car from moving accidentally

When the elevator is in the leveling device and the door is not closed, if the elevator moves unexpectedly, the cump safety device will immediately activate the protection to ensure the operation of the elevator.

VVVF variable frequency gantry crane system

Advanced VVVF transformer and synchronous control technology are applied to elevator door motor system to ensure smooth and quiet opening and closing of elevator door.

Buffer

It can absorb the normal impact energy of the elevator to the maximum extent and ensure the safety of the passenger elevator.

Speed governor

When the elevator exceeds the standard speed limit, the speed limiter will cut off the safety circuit to ensure that the elevator stops running.

Safety gear

When the elevator exceeds the standard speed, the safety gear will function through the speed limiter linkage device to ensure that the elevator stops safely.

Reliability

The traction system, door system and other main component systems have passed strict reliability tests to ensure the reliable operation of the elevator under long-term and heavy-load conditions.

The button with anti-drop design is sturdy and reliable, and can withstand improper use. Efficient permanent magnet synchronous gearless traction machine.

- ◆High magnetic flux density electromagnetic structure, high efficiency and low noise.
- ◆A more uniform force and a more stable structure effectively reduce the wear of the traction wire rope and prolong the service life of the bearing.
- ◆High peak torque and strong overload capacity make the operation stable and reliable.

Energy saving

We are committed to improving space utilization and reducing customers' construction costs.

PM synchronous tractor and integrated controller have compact size and layout, which can reduce the area of the machine room.

The area of the machine room is the same as that of the hoistway. Only accounts for 50% of the traditional computer room area.

The machine roomless elevator saves more building space.

Adhering to the product development concept of "energy saving and environmental protection", we use advanced green technology to produce low energy consumption products.

The energy efficiency rating of the product reaches A level.

Digital frequency conversion technology and permanent magnet synchronous traction technology can adjust the motor current in real time, and greatly reduce the average current during the operation of the motor to save energy.

The lighting system uses LED technology, which has the characteristics of high efficiency, energy saving, long life, environmental protection, no radiation, and easy maintenance, creating a low-carbon life.

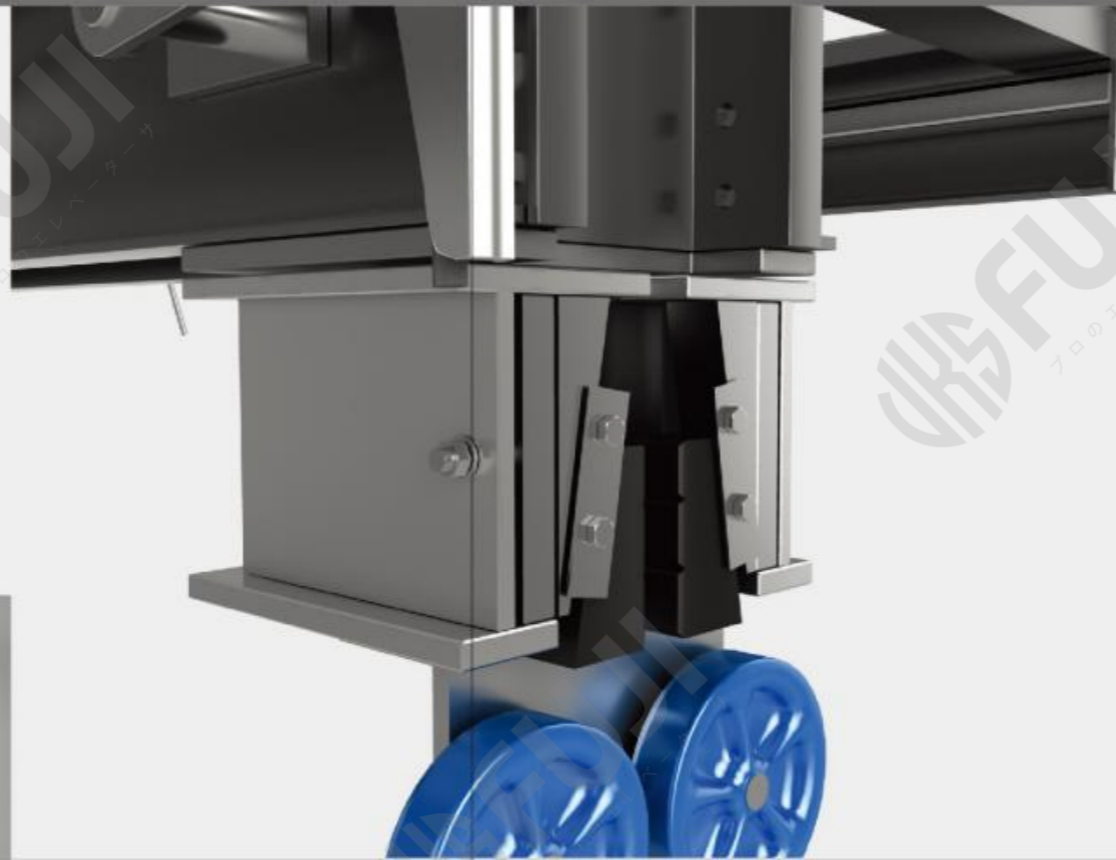
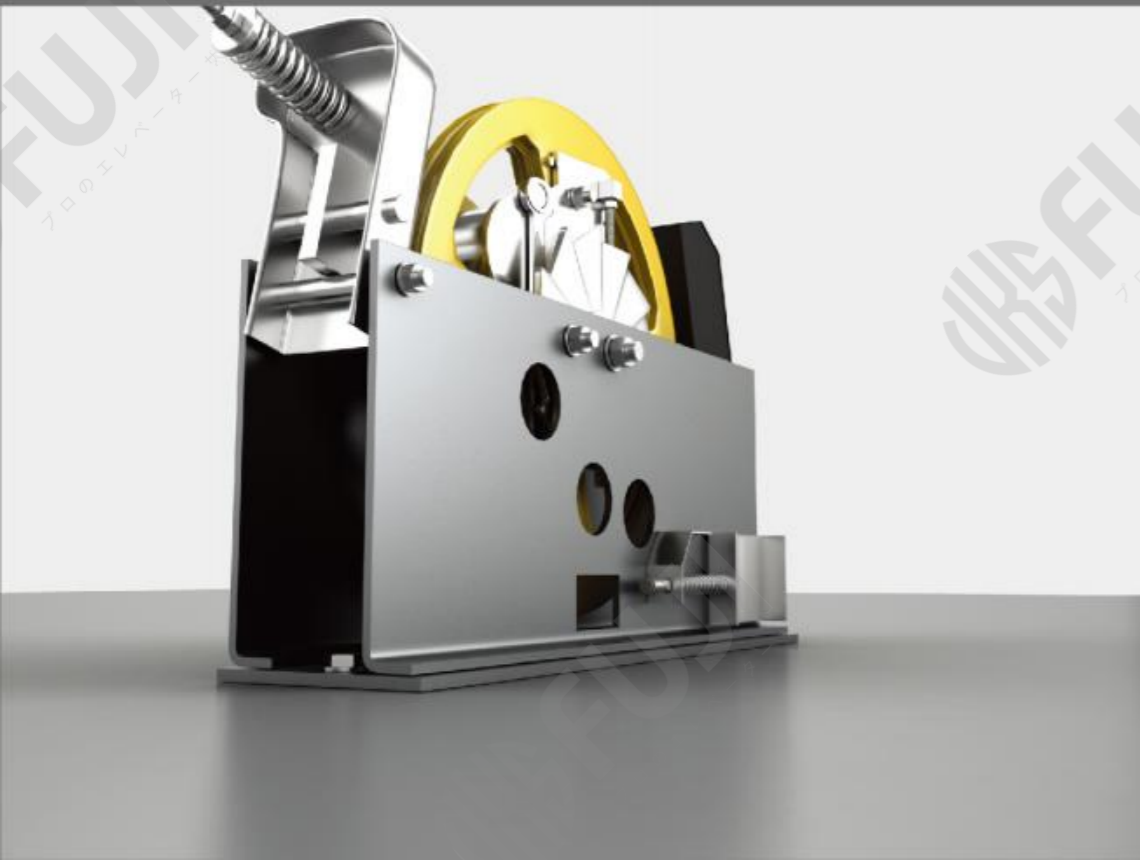

Green low-carbon fully enjoy a natural and harmonious green space

Energy feedback technology

The energy feedback device enables the conversion of the heat energy produced in the elevator operation into electric energy and feedback to the power grid. In this case, the energy utilization is maximized with an energy-saving ratio of 30% above.

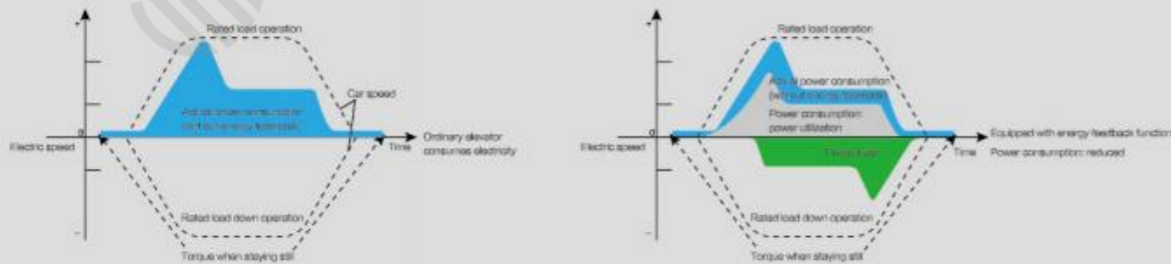

Top-class technology intelligent innovation

Top advanced door operator system

The door operator control system of our company applies dual control systems. One group is controlled by main controller of control cabinet, the other one by door operator controller, which greatly reduces non-opening accidents due to trouble of door machine control.

Fully computerized integrative and intellectual control system

Our company gives a full play of human intelligence by variable frequency, speed governor elevator technology with top grade, fully computerized, modular data intellectual network control. It brings about the more perfect and flexible systematic functions. It executes the most secure, accurate, effective management control to the elevator operation. Under the conditions of not changing the conveying configuration, its special-purpose modular structure is more convenient for the elevator renewal and upgrading in future.

Light curtain door protection system

It forms light curtain barrier in front of elevator door with 94 infrared light beams protection. It sensitively reacts to any person / object that enters into the probing plane with high safety properties. It quickly re-starts door machine opening to prevent from clamping.

Liquid crystal touch operation system

Liquid crystal touch screen is simple in operation and convenient in installation. User only needs to touch graphic button in screen, then touch feedback system in screen can drive various connection devices according to systematic program. It applies touch screen to produce the first-class user operation experience. Let's feel brand-new human-machine communication and interaction!



Small machine room elevator

Internal and external repair, quality of construction

Today with the flourishing developments in the construction industry, elevator is indispensable to the buildings. passenger elevator is high quality elevator that integrates the excellent performances and comfortable experience into one. It is your best choice in residence, commercial building, office building, commercial center, hotel, restaurant etc.

Reasonable construction layout

Machine room is exactly the same as the well. It reduces 250mm of machine room height. It pre-leaves a larger building space.

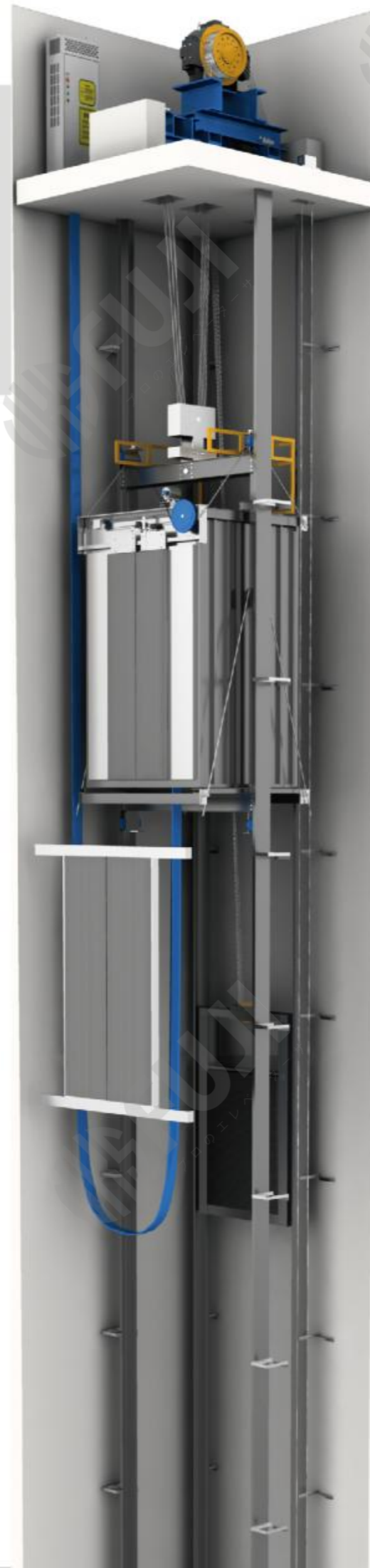
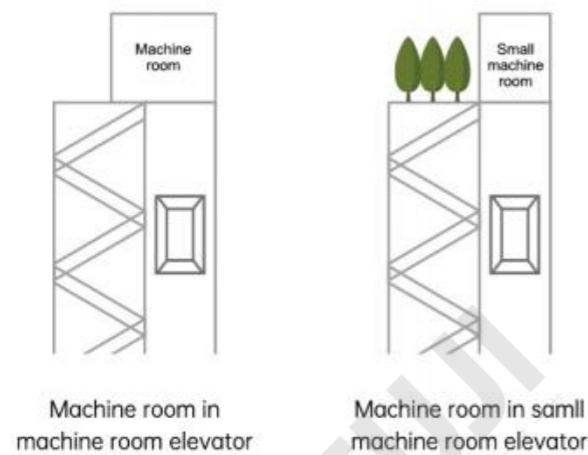

Machine roomless elevator

It easily merges with the building and enhances the building values

With machine room less structure, control cabinet and traction are placed in the shaft flexibly. It saves construction area and with artistic and simple shape, which reduces comprehensive construction cost and leaves design space for architects and developers.

Low energy consumption, space-saving

It is low energy consumption-based. It fully considers building space's utilization rate and cost. Using compact layout and flexible design style and cleverly integrating all kinds of buildings, it is the first choice for modern individualized buildings.

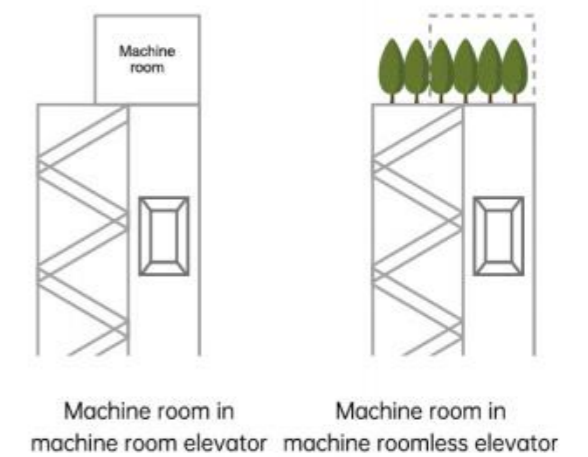



Passenger elevator

Our company the flourishing developments in the construction industry, elevator is indispensable to the buildings. Express passenger elevator is high quality elevator that integrates the excellent performances and comfortable experience into one. It is your best choice in residence, commercial building, office building, commercial center, hotel, restaurant etc. Express passenger elevators are ample in varieties, e.g. passenger elevator with machine room, small machine room elevator, machine room-less elevator, low speed elevator, medium speed elevator, high speed elevator. Express passenger elevators with complete specifications and beautiful decoration satisfy different requirements from various users in all walks of life in an omni-bearing way.

Passenger elevator car decoration



CMCP-001

STANDARD

Ceiling: Hairline stainless steel, LED lights, acrylic dome top

Car wall: Hairline stainless steel

Handrail: None

Floor: PVC(Standard), Marble(Optional)



CMCP-002

OPTIONAL

Ceiling: Mirror stainless steel, acrylic transparent board, LED lights

Car wall: Mirror stainless steel, hairline stainless steel

Handrail: None

Floor: PVC(Standard), Marble(Optional)



CMCP-003

OPTIONAL

Ceiling: Mirror stainless steel, ached roof, LED lights

Car wall: Mirror etched stainless steel for center plate, titanium etched and hairline stainless steel for the auxiliary plate

Handrail: Stainless steel single flat

Floor: PVC(Standard), Marble(Optional)



CMCP-004

OPTIONAL

Ceiling: Mirror stainless steel, acrylic transparent board, LED lights

Car wall: Mirror etched stainless steel for center plate, auxiliary hairline stainless steel

Handrail: Stainless steel single round tube on both sides

Floor: PVC(Standard), Marble(Optional)



CMCP-005

OPTIONAL

Ceiling: Mirror stainless steel, acrylic transparent board, LED lights

Car wall: Mirror etched stainless steel, auxiliary hairline stainless steel

Handrail: Stainless steel single flat

Floor: PVC(Standard), Marble(Optional)



CMCP-006

OPTIONAL

Ceiling: Mirror stainless steel, acrylic transparent board, LED lights

Car wall: Etched stainless steel, auxiliary mirror stainless steel

Handrail: None

Floor: PVC(Standard), Marble(Optional)



CMCP-007

OPTIONAL

Ceiling: LED lights

Car wall: Etching mirror stainless steel

Handrail: Stainless steel single round tube

Floor: PVC(Standard), Marble(Optional)



CMCP-008

OPTIONAL

Ceiling: Mirror stainless steel, acrylic transparent board, LED lights

Car wall: Mirror etched stainless steel for center plate, auxiliary wood grain steel plate

Handrail: None

Floor: PVC(Standard), Marble(Optional)



CMCP-009

OPTIONAL

Ceiling: Middle image vault, stainless steel plates on both sides, LED down

Car wall: Mirror etched stainless steel for center plate, auxiliary hairline stainless steel

Handrail: Mirror stainless steel single round tube

Floor: PVC(Standard), Marble(Optional)

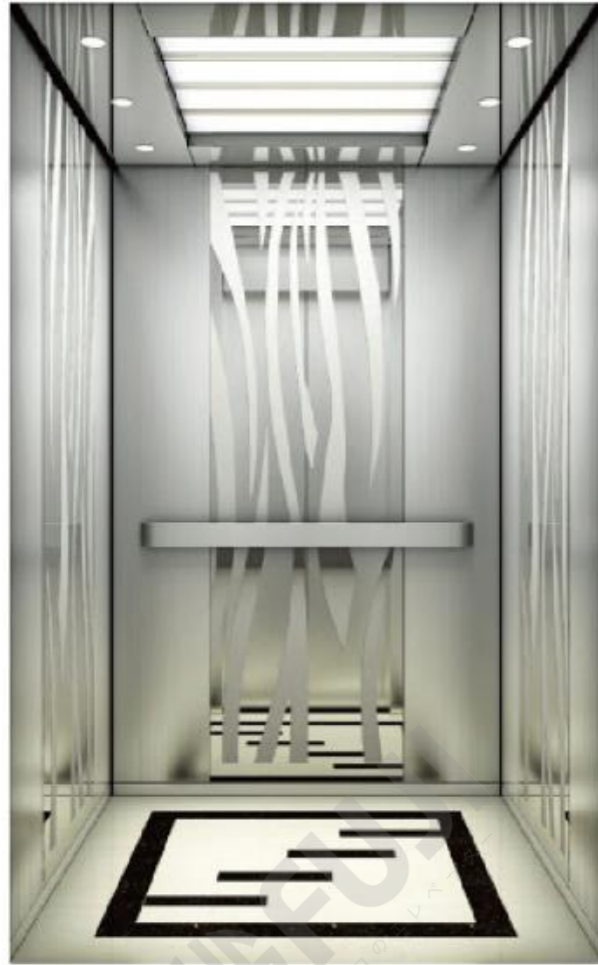

CMCP-010

OPTIONAL

Ceiling: Mirror stainless steel, acrylic transparent board, LED lights

Car wall: Mirror etched stainless steel for center plate, auxiliary hairline stainless steel

Handrail: Stainless steel single flat

Floor: PVC(Standard), Marble(Optional)



CMCP-011

OPTIONAL

Ceiling: Mirror stainless steel, acrylic transparent board, LED lights

Car wall: Mirror etched stainless steel for center plate, auxiliary hairline stainless steel

Handrail: Stainless steel single round tube

Floor: PVC(Standard), Marble(Optional)



CMCP-012

OPTIONAL

Ceiling: LED lights, downlights, mirror stainless steel

Car wall: Line etching stainless steel, mirror stainless steel

Handrail: None

Floor: PVC(Standard), Marble(Optional)



CMCP-013

OPTIONAL

Ceiling: Mirror stainless steel with down light

Car wall: Three sides car wall middle plate mirror etched stainless steel, auxiliary hairline stainless steel

Handrail: Stainless steel single round tube on both sides

Floor: PVC(Standard), Marble(Optional)



CMCP-014

OPTIONAL

Ceiling: Mirror stainless steel frame, transparent organic lam post frame with acrylic craft board hidden lamp belt

Car wall: Mirror etched stainless steel for center plate, auxiliary hairline stainless steel

Handrail: Stainless steel single round tube

Floor: PVC(Standard), Marble(Optional)



CMCP-015

OPTIONAL

Ceiling: LED lights, downlights, mirror stainless steel

Car wall: Half mirror stainless steel, hairline stainless steel

Handrail:Stainless steel flat on three sides

Floor: PVC(Standard), Marble(Optional)



CMCP-016

OPTIONAL

Ceiling: Downlights, stainless steel

Car wall: Etching mirror stainless steel

Handrail:None

Floor: PVC(Standard), Marble(Optional)



CMCP-017

OPTIONAL

Ceiling: Downlights, mirror stainless steel

Car wall: Etching mirror stainless steel, hairline stainless steel

Handrail:Stainless steel round tube on three sides

Floor: PVC(Standard), Marble(Optional)



CMCP-018

OPTIONAL

Ceiling: Mirror stainless steel, double arched acrylic plate, LED lights

Car wall: Sprayed steel plate, auxiliary mirror etched stainless steel

Handrail: Stainless steel single round tube

Floor: PVC(Standard), Marble(Optional)



CMCP-019

OPTIONAL

Ceiling: Titanium gold mirror etched stainless steel, acrylic decorative lights, LED lights

Car wall: Titanium gold mirror etched stainless steel, titanium stainless steel and pattern plate

Handrail: None

Floor: PVC(Standard), Marble(Optional)



CMCP-020

OPTIONAL

Ceiling: Titanium gold mirror etched stainless steel, acrylic decorative lights

Car wall: Titanium gold mirror stainless steel, etched

Handrail: None

Floor: PVC(Standard), Marble(Optional)



CMCP-021

OPTIONAL

Ceiling: Steel plate paint frame, surrounded by champagne gold mirror with LED down light

Car wall: Champagne gold mirror, hairline etching pattern combination

Handrail: None

Floor: PVC(Standard), Marble(Optional)



CMCP-022

OPTIONAL

Ceiling: Titanium gold mirror stainless steel, arched acrylic transparent plate

Car wall: Titanium gold mirror stainless steel, etched

Handrail: Titanium gold stainless steel + wood grain round tube

Floor: PVC(Standard), Marble(Optional)



CMCP-023

OPTIONAL

Ceiling: Titanium gold mirror stainless steel, acrylic translucent board, LED light

Car wall: Titanium gold mirror etched stainless steel, ceramic tile or slate

Handrail: Titanium gold stainless steel + wood grain round tube

Floor: PVC(Standard), Marble(Optional)



CMCP-024

OPTIONAL

Ceiling: Titanium gold mirror stainless steel, LED

Car wall: Titanium gold mirror stainless steel, titanium gold mirror etched stainless steel, wood decoration

Handrail: Titanium gold stainless steel single flat

Floor: PVC(Standard), Marble(Optional)

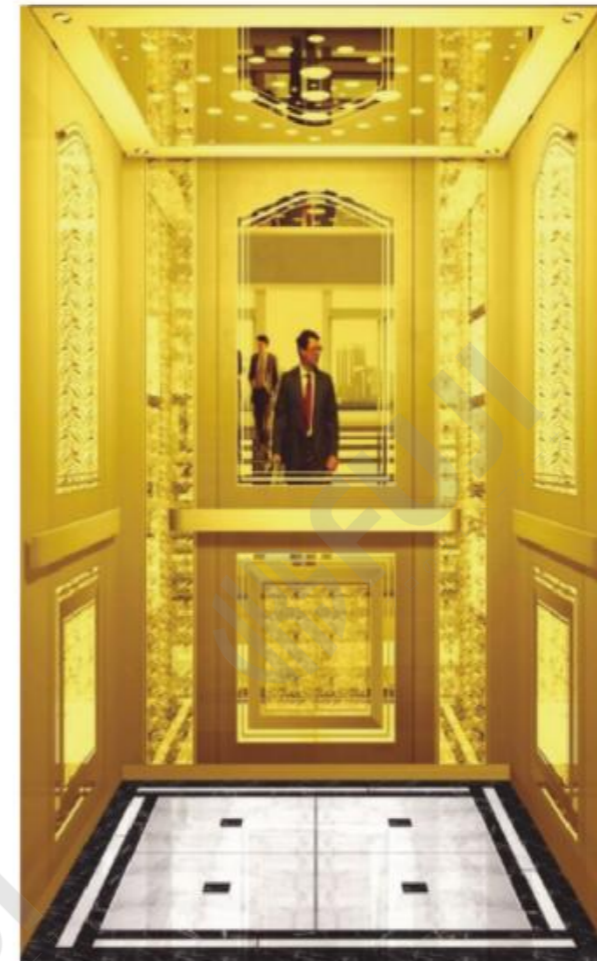

CMCP-025

OPTIONAL

Ceiling: Titanium gold mirror stainless steel, acrylic decorative lights

Car wall: Titanium gold stainless steel, titanium gold mirror etched stainless steel

Handrail: Titanium gold stainless steel single flat

Floor: PVC(Standard), Marble(Optional)



CMCP-026

OPTIONAL

Ceiling: Milky white paint frame, organic lamp post, stainless steel mirror in the middle, LED lights all around

Car wall: Titanium gold mirror stainless steel, titanium gold mirror etched stainless steel

Handrail: Titanium gold stainless steel single flat

Floor: PVC(Standard), Marble(Optional)



CMCP-027

OPTIONAL

Ceiling: Titanium gold mirror stainless steel, acrylic decorative lights

Car wall: Titanium gold mirror etched stainless steel

Handrail: Titanium gold etched stainless steel three round tube on three sides

Floor: PVC(Standard), Marble(Optional)



CMCP-028

OPTIONAL

Ceiling: Titanium gold mirror stainless steel, double arched acrylic light plate, LED lights

Car wall: Titanium gold etched stainless steel

Handrail: Titanium gold stainless steel round tube

Floor: PVC(Standard), Marble(Optional)



CMCP-029

OPTIONAL

Ceiling: Titanium gold mirror stainless steel, double arched acrylic light plate, LED lights

Car wall: Titanium gold mirror etched stainless steel

Handrail: Solid wood decoration, titanium gold stainless steel single round tube on both sides

Floor: PVC(Standard), Marble(Optional)



CMCP-030

OPTIONAL

Ceiling: Titanium gold mirror stainless steel, acrylic lighting, LED lighting

Car wall: Titanium gold stainless steel, titanium gold mirror etched stainless steel

Handrail: None

Floor: PVC(Standard), Marble(Optional)



CMCP-031

OPTIONAL

Ceiling: Titanium gold mirror stainless steel, acrylic lighting, LED lighting

Car wall: Titanium gold mirror etched stainless steel

Handrail: None

Floor: PVC(Standard), Marble(Optional)



CMCP-032

OPTIONAL

Ceiling: Rose gold frame with down light, silver tin foil in the middle

Car wall: Rose gold mirror etched, middle hard foreshin decoration

Handrail: Rose gold plated stainless steel single round tube on both sides

Floor: PVC(Standard), Marble(Optional)



CMCP-033

OPTIONAL

Ceiling: Titanium gold mirror stainless steel, acrylic light-transmitting board, LED lighting

Car wall: Titanium gold mirror etching, titanium gold sandblasting process

Handrail: None

Floor: PVC(Standard), Marble(Optional)



CMCP-034

OPTIONAL

Ceiling: Titanium gold mirror stainless steel
european style ceiling lamp

Car wall: Titanium gold mirror stainless steel, wood
grain trim, leather soft-roll

Handrail: Wood grain round handrail

Floor: PVC(Standard), Marble(Optional)



CMCP-035

OPTIONAL

Ceiling: Wood frame, LED downlight

Car wall: Rose gold mirror stainless steel, frosted
etching process

Handrail: Rose gold mirror stainless steel, frosted
etching process round tube handrail

Floor: PVC(Standard), Marble(Optional)



CMCP-036

OPTIONAL

Ceiling: Titanium gold mirror stainless steel, LED
light, mirror etched decorative hidden light
strip

Car wall: Titanium gold mirror stainless steel,
titanium gold mirror etching

Handrail: Titanium gold round handrail

Floor: PVC(Standard), Marble(Optional)



CMCP-037

OPTIONAL

Ceiling: Black titanium mirror, LED lighting

Car wall: Black titanium mirror etched

Handrail: None

Floor: PVC(Standard), Marble(Optional)



CMCP-038

OPTIONAL

Ceiling: Titanium gold mirror stainless steel, acrylic lighting

Car wall: Titanium gold mirror etched stainless steel

Handrail: Titanium gold stainless steel + wood grain round tube

Floor: PVC(Standard), Marble(Optional)



CMCP-039

OPTIONAL

Ceiling: Titanium gold mirror stainless steel, LED lighting

Car wall: Titanium gold mirror etching, titanium gold mirror

Handrail: None

Floor: PVC(Standard), Marble(Optional)



CMCP-040

OPTIONAL

Ceiling: Titanium mirror etched stainless steel, LED lights

Car wall: Titanium mirror etched stainless steel, auxiliary mirror etched stainless steel

Handrail: Titanium mirror stainless steel double round tube

Floor: PVC(Standard), Marble(Optional)

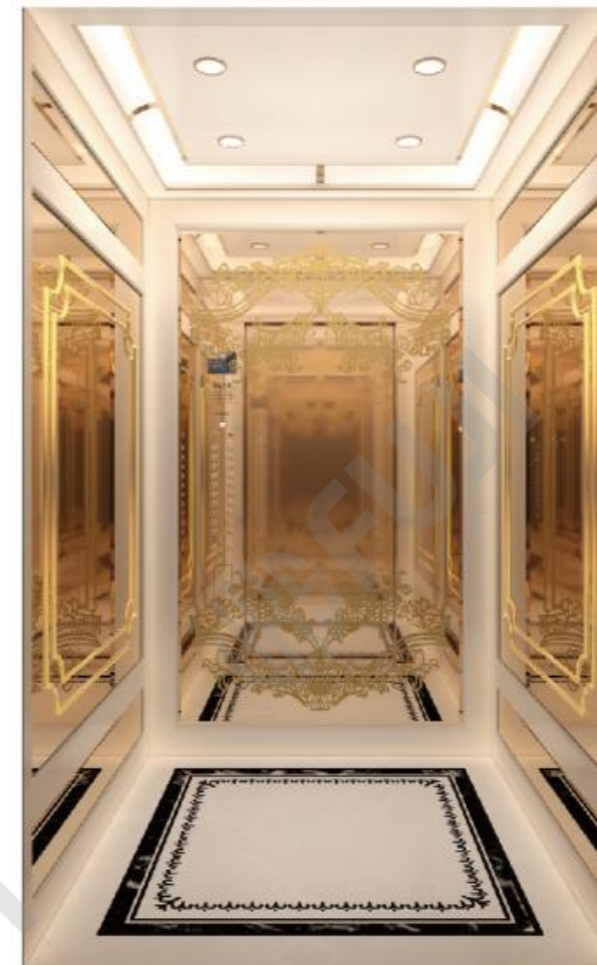

CMCP-041

OPTIONAL

Ceiling: Wooden shape, acrylic lighting, LED lights

Car wall: Solid wood paint, titanium mirror etched stainless steel

Handrail: None

Floor: PVC(Standard), Marble(Optional)



CMCP-042

OPTIONAL

Ceiling: Rose gold mirror stainless steel, acrylic lighting, LED lighting

Car wall: Rose gold stainless steel, rose gold mirror etched stainless steel

Handrail: None

Floor: PVC(Standard), Marble(Optional)



CMCP-043

OPTIONAL

Ceiling: Wood frame, acrylic lighting, LED lighting

Car wall: Rose gold mirror etched stainless steel, wood decoration

Handrail: Stainless steel flat

Floor: PVC(Standard), Marble(Optional)



CMCP-044

OPTIONAL

Ceiling: Wood frame, LED light

Car wall: Wood decoration, rose gold mirror etched stainless steel

Handrail: Wood single flat on both wall

Floor: PVC(Standard), Marble(Optional)



CMCP-045

OPTIONAL

Ceiling: Wood frame, LED downlight

Car wall: Marble inlay, black titanium gold mirror etching stainless steel

Handrail: Wood grain round handrail

Floor: PVC(Standard), Marble(Optional)

Observation elevator

Super enjoyment of mobile scene

Fine and exelcive observation elevator enhances building grade. It highlights the whole building. Observation elevator is a mobile scene. It has fine and exquisite visual aesthetics, perfect and comfortable travel. It applies modern new material and new fully computerized, vector type variable frequency speed regulation (VVVF) control technology. It combines with data network system, modular structure, the latest machining craft & technology.



Fiberglass reinforced plastic construction

It perfectly displays an overall compact and beautiful space. It can carry out different construction layout designs. It is prompt and convenient. round, half-round, square etc. are available for your free choice.

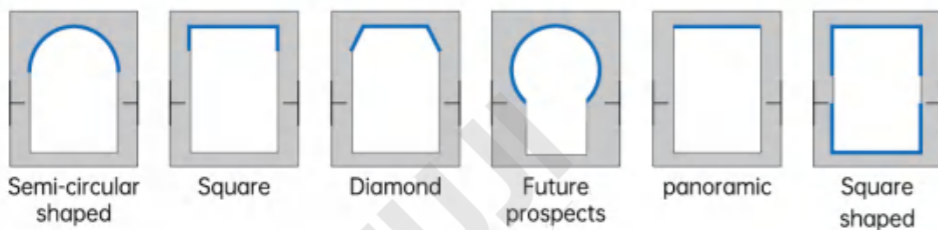

Observation elevator car decoration



CO/CON-01

OPTIONAL

Car cover:
Hairline stainless steel

Observation wall:
Safety laminated glass

Decoration ceiling:
Mirror stainless steel, LED lights, acrylic decorative lights

Car wall:
Hairline stainless steel

Handrail:
Stainless steel tube

Floor: PVC(Standard), Marble(Optional)



CO/CON-02

OPTIONAL

Car cover:
Hairline stainless steel

Observation wall:
Safety laminated glass

Decoration ceiling:
Mirror stainless steel, LED lights

Car wall:
Hairline stainless steel

Handrail:
Stainless steel tube

Floor: PVC(Standard), Marble(Optional)



CO/CON-03

OPTIONAL

Car cover:
Steel plate with spraying

Observation wall:
Safety laminated glass

Decoration ceiling:
Mirror stainless steel, LED lights, acrylic decorative lights

Car wall:
Hairline stainless steel

Handrail:
Stainless steel tube

Floor: PVC(Standard), Marble(Optional)

Observation elevator car decoration



CO/CON-04

OPTIONAL

Car cover:
Hairline stainless steel

Observation wall:
Safety laminated glass

Decoration ceiling:
White ceiling light plus downlight

Car wall:
Hairline stainless steel

Handrail:
Stainless steel three tubes

Floor: PVC(Standard),
Marble(Optional)

CO/CON-05

OPTIONAL

Car cover:
Steel plate banking and
decoration lighting

Observation wall:
Safety laminated glass

Decoration ceiling:
Hairline stainless steel,
acrylic lighting

Car wall:
Hairline stainless steel

Handrail:
Stainless steel single tube

Floor: PVC(Standard),
Marble(Optional)

CO/CON-06

OPTIONAL

Car cover:
Hairline stainless steel

Observation wall:
Safety laminated glass

Decoration ceiling:
Hairline stainless steel,
acrylic lighting

Car wall:
Hairline stainless steel,
mirror etched stainless steel

Handrail:
Stainless steel single tube

Floor: PVC(Standard),
Marble(Optional)

CO/CON-07

OPTIONAL

Car cover:
Black titanium stainless steel

Observation wall:
Safety laminated glass

Decoration ceiling:
Black titanium mirror stainless steel,
acrylic transparent plate, LED light

Car wall:
Black titanium mirror stainless steel

Handrail:
Black titanium stainless steel flat handrail

Floor: PVC(Standard),
Marble(Optional)

CO/CON-08

OPTIONAL

Car cover:
Champagne/Gold hairline stainless steel

Observation wall:
Safety laminated glass

Decoration ceiling:
Champagne/Gold mirror stainless steel,
acrylic transparent plate, LED light

Car wall:
Champagne/Gold mirror stainless steel

Handrail:
Champagne/Gold stainless steel tube

Floor: PVC(Standard),
Marble(Optional)

CO/CON-09

OPTIONAL

Car cover:
Titanium mirror stainless steel

Observation wall:
Safety laminated glass

Decoration ceiling:
Acrylic translucent plate, LED downlight

Car wall:
Titanium mirror stainless steel

Handrail:
Titanium mirror flat handrail

Floor: PVC(Standard),
Marble(Optional)

Observation elevator car decoration



CO/CON-10

OPTIONAL

- Car cover:**
Titanium gold etching, steel plate baked enamel
- Observation wall:**
Safety laminated glass
- Decoration ceiling:**
Steel plate baked enamel, acrylic lighting decoration, LED lights
- Car wall:**
Titanium gold mirror etched stainless steel
- Handrail:**
Titanium mirror double tube handrail
- Floor:** PVC(Standard),
Marble(Optional)



CO/CON-11

OPTIONAL

- Car cover:**
Titanium stainless steel and decorative lights
- Observation wall:**
Safety laminated glass
- Decoration ceiling:**
Titanium stainless steel, acrylic decorative lights
- Car wall:**
Titanium gold hairline stainless steel landing door has glass
- Handrail:**
Hairline stainless steel tube
- Floor:** PVC(Standard),
Marble(Optional)



CO/CON-12

OPTIONAL

- Car cover:**
Titanium stainless steel and decorative lights
- Observation wall:**
Safety laminated glass
- Decoration ceiling:**
Painted steel plate, acrylic lighting
- Car wall:**
Titanium mirror stainless steel
- Handrail:**
Titanium stainless steel tube
- Floor:** PVC(Standard),
Marble(Optional)

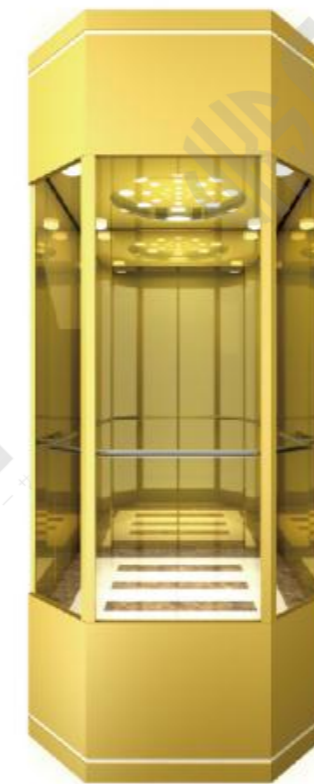

CO/CON-13

OPTIONAL

- Car cover:**
Titanium stainless steel
- Observation wall:**
Safety laminated glass
- Decoration ceiling:**
Titanium mirror stainless steel, LED lights
- Car wall:**
Titanium mirror stainless steel
- Handrail:**
Stainless steel single tube
- Floor:** PVC(Standard),
Marble(Optional)



CO/CON-14

OPTIONAL

- Car cover:**
Steel spraying, hairline stainless steel
- Observation wall:**
Safety laminated glass
- Decoration ceiling:**
Hairline stainless steel, LED lights, acrylic decorative lights
- Car wall:**
Hairline stainless steel, steel spraying
- Handrail:**
Stainless steel tube
- Floor:** PVC(Standard),
Marble(Optional)



CO/CON-15

OPTIONAL

- Car cover:**
Steel plate baking varnish, acrylic lighting
- Observation wall:**
Safety laminated glass
- Decoration ceiling:**
Titanium mirror stainless steel, painted craft board, LED downlight
- Car wall:**
Titanium mirror stainless steel
- Handrail:**
Titanium mirror single tube floor handrail
- Floor:** PVC(Standard),
Marble(Optional)

Observation elevator car decoration

360 degree/ circle elevator

Description: Technology advancements go a long way in making our lives better. Pneumatic elevators, for instance, are revolutionising vertical transportation and providing amazing experiences for customers. The unique circular design of these panoramic elevators offers a 360 ° degree view as you travel from floor to floor, making them beautiful additions to any residence. During the ascent or descent, you will enjoy cool, ambient temperatures as a cabin fan circulates the air in the cabin and an LED light keeps the cabin lit.

CO/CON-16

OPTIONAL

Car cover:

Titanium gold stainless steel or titanium gold mirror stainless steel

Observation wall:

Safety laminated glass

Decoration ceiling:

Titanium mirror stainless steel, painted craft board, LED downlight

Car wall:

Safety laminated glass

Handrail:

None

Floor: PVC(Standard),
Marble(Optional)

Color: Black, silver or white powder coating as standard; custom colors available





Moving walk

Let's pleasantly enjoy a happy life in movements

Moving walk can not only meet the transportation problem of the large flow of people, and can meet the walking long distances and transport, baggage car, baby carriages, shopping cart, disability and other vehicles, so that people ride especially feeling relaxing down the stairs on the occasion of the shopping, greatly and people's travel and shopping.



Escalator

Escalator series products have been products according to the current international standard and Chinese standard. It fully applies the novel materials and advanced technology both at home and abroad to design and manufacture the escalators. It has the features such as smooth running, low noise, fine durability, convenient repair, fine and exquisite structure, consummate lift-way, remarkable belt-way, attractive outline model, magnificent design style with gentle modern flavor. A safe, cozy and beautiful escalator can let you enjoy the pleasant and comfortable moment every day.

Reliability

The drive unit that uses high-precision reducer and 6-pole motor features high torque, low noise, stable transmission and good shock absorption.

Finite element analysis is used in truss system design to achieve stable structure, high rigidity and strong supporting capacity. Angle steel is applied in the structure and corrosion.

High-duty structural design, reliable transmission components and different waterproof and anticorrosion treatments enable the product to adapt to various installation environments.

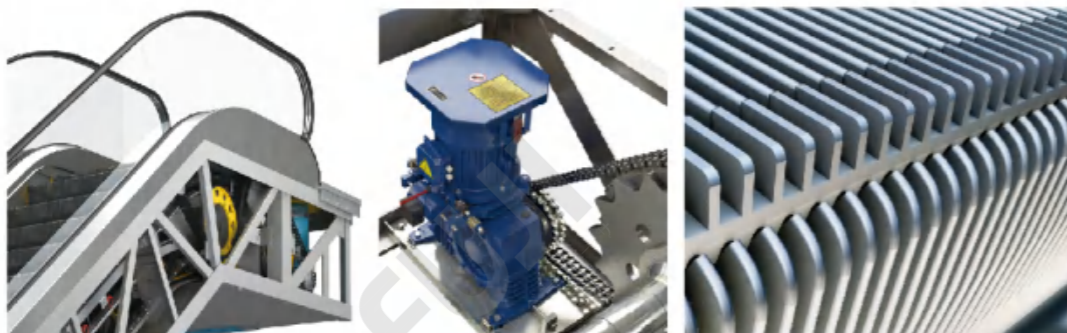

Leading technology produces smooth traffic & transport

- **Demarcation lamp**

Soft and green fluorescent light sends out from the engaging teeth in-between two adjacent steps (treads) in up / down end. It reminds the passengers to pay attention to the step entry / exit horizontal section. It thus enhances the travel safely.

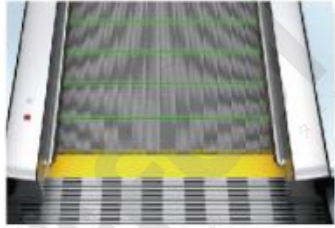

- **Skirt panel brush**

The full skirt deflector provides protection against the clamped risk between the skirt panel and the step.

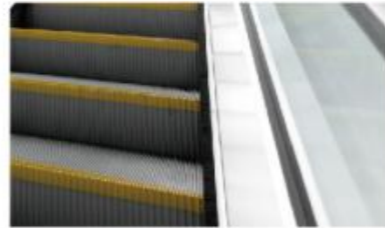

- **Handrail entry safety protection**

Protection against risk of foreign matters being jammed into handrail entry.



- **Drive chain safety device**

Once drive chains are broken, this device shall cut off the power supply of motor and brake and at the same time the drive ratchet shall stop the operation of passenger conveyor.



- **Antibiotic handrail**

The antibiotic handrail can prevent pathogen transmission effectively and the ride be made in safe and sanitary environment.



- **Emergency stop button**

Once this button is pressed, the passenger conveyor comes into an emergency stop.



- **Side guide high accuracy step guide rail system**

High rigidity big profile guide rail with nose used as transverse step positioning, guarantee the minimum gap between the skirt and step, decrease the possibility of objects clamp in between.

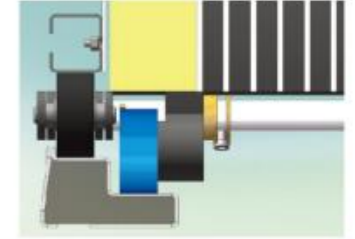

- **Comb safety devices**

Front ends of comb plates are installed on springs. If any foreign substance is nipped between moving escalator steps and static comb plates; such plates will move in vertical or backward directions, and trigger the safety switches monitoring at both sides of the plates, and the escalators will be automatically stopped.

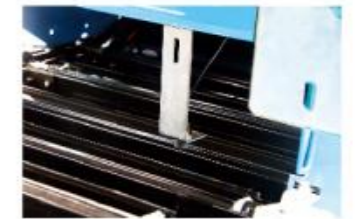

- **Automatic lubricator**

It is controlled by micro-computer. It gives lubricating signal within the set period. It automatically connects with hydraulic pump for oiling and lubrication.

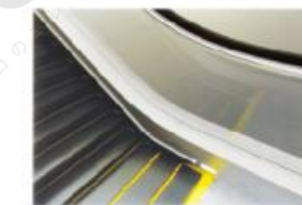

- **Step loss protection device**

The detector is in driving station and steering station respectively. It ensures that the gap out of step (tread) loss does not appear in the entry in up / down motion. Driving station and steering station sets protective detection functions. They shall be verified respectively under normal operation conditions. After the device acts, it can only be reset manually.

Optional function

Skirting panel lighting

White / Blue / Red

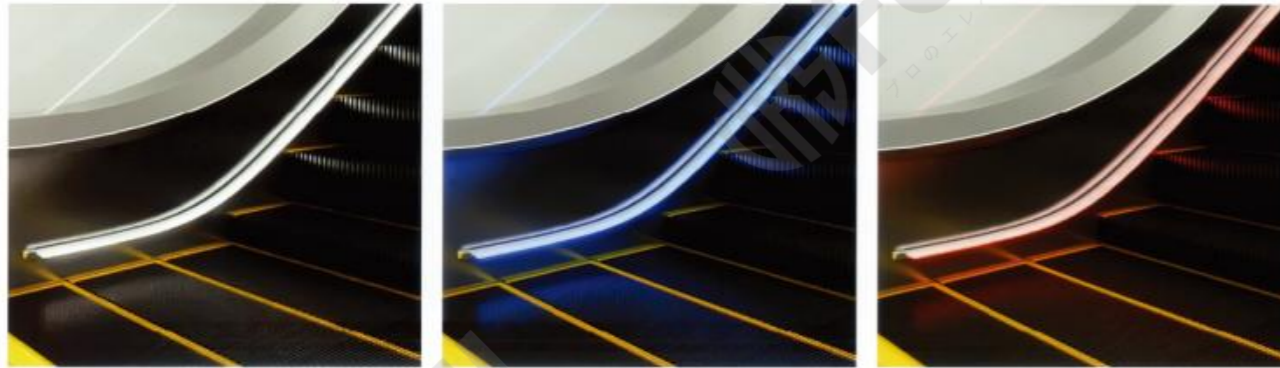

Handrail color

Black / Gray / Red / Blue



Step

Stainless steel step



Aluminum alloy step

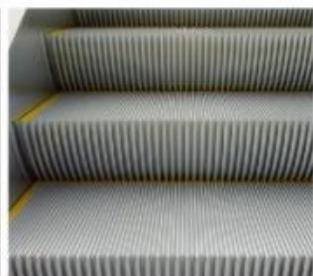

Comb

Aluminium alloy

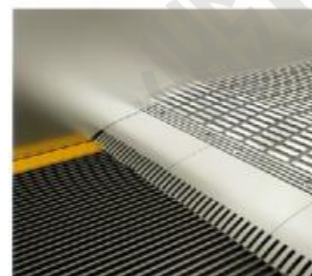

Floor plate

Aluminium alloy

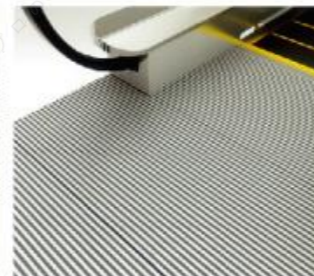

Shopping cart escalator



Let's enjoy the pleasant shopping process

The shopping cart into the escalator can make the shopping cart along with the rail and escalator synchronous step forward, which reduces the original flat elevator occupies a large space and long-distance weakness while reducing the burden of consumers shopping.

Overall planning is easy for maintenance

In order to better ensure the coordination of the product equipment and application environment, we comprehensively analyze the use environment. We offer the most optimized solution plan. At the same time of considering that the product properties satisfy the building and passenger flow transport requirements, we enhance the use performance to the greatest extent for you. It is thus convenient for later maintenance and upgrading. Within the use life circle of the building, all the parts can be renewed and upgraded. We reduce the operation cost to the maximum degree. We thus fulfill the transport purpose of simple, flexible, durable, high-cost benefit.



Security fence



Shopping cart running track



Shopping cart escalator entrance



Shopping cart escalator export

Hospital elevator

Caring your life Bold

Hospital elevators are not only used to transport passengers, but also have special and strict requirements for the performance due to the special usage. Hospital elevators can run smoothly and comfortably. Creating a quiet, elegant space for the passengers.



Ceiling: Painted steel plate, LED lighting
 Ventilation: Axial fan
 Car wall: Hairline stainless steel
 Handrail: Double flat stainless steel
 Floor: PVC
 Landing door: Hairline stainless steel



Dumbwaiter elevator

Dumbwaiter elevator using industrial computer (PLC) or computer control, complete specifications, novel structure, fine workmanship, with safe, reliable stable, easy to operate. The car and landing doors are made by high quality stainless steel plate production lines, luxury and beautiful. It is widely used in hotels, restaurants and other units, it is warmly welcome by users.



Car elevator



It deducts extraordinary travel experiences.

Automobile elevator introduces well-developed international car elevation technology. It develops and manufactures automobile elevator through absorption, transformation and improvement. Advanced technology removes shaking car problem due to noise, burdened traction system and uneven force to elevator car. It optimizes characteristics of the product series.



Dual operation panels design



Special circuit control and display system



Safety guide device



Front-and-aft opening elevator car

Freight elevator

Bear with any heavy load at ease

Freight elevator applies fully computerized modular elevator special-purpose control system, effective and reliable drive mode, gentle and sensitive VVVF variable frequency door machine. It can flexibly carry with any heavy loads at ease under various working conditions. High strength car structure, anti-collision strip, light curtain door can satisfy various goods transport uses. It adapts to different building structures. It can competently bear with any heavy loads at ease. It creates a brand-new goods delivery concept.



It saves 25% of total elevator area.



It reduces 40% of space occupation rate.



Stair elevator

Intellectual auxiliary hoist intellectual hoist electric balancing device

Excellent design of intellectual hoist Ai system ensures that operator is in the correct ergonomics position. Meanwhile, it can fully control the load. Control handle is equipped with programming software. It can be tailor-made according to the clients' application requirements.

Linear instinct induced handle controls the intellectual hoist servo system. Therefore it can train less operators. Handle is reacted by instant touch. Hold and operate it to move the load.



Intellectual straight-rail stair chair lift

Stair chair lift can help the old / disabled to independently up / down the stairs. It solves the problem of difficult up / down with convenient installation. It operates along the rail left / right of the stairs. It does not destroy any family facilities. It is especially suitable for decorated houses. Stair chair lift applies combination of steel structure, aluminum alloy casting and combustible plastic housing with safe and reliable properties, popular and attractive outline.



Barrier-free elevator

Barrier-free elevator is applicable for the people in armchairs, visually disabled. Stretcher can be put into and used in the elevator. Barrier-free elevators must be installed in public buildings. Barrier-free elevator has obstacle-free design. It applies modern technology to construct and transform the environments. It provides a safe space with convenient action for broad disabled people. It creates an equal environment for the people.



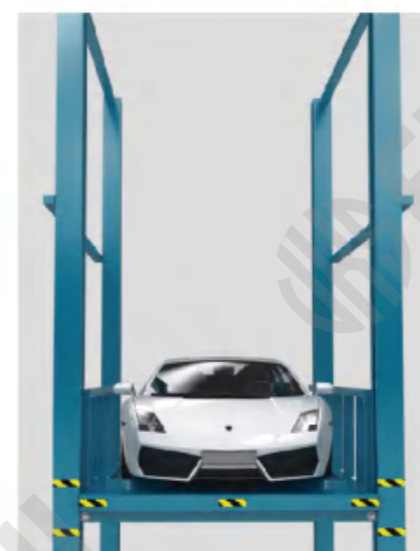

Lifting platform

Our company hoist is bright and abroad. It is economical and practical. It features as prompt and convenient transport, safe, reliable, smooth operation, large loading capacity etc. It is the best goods transport tool in the factory, warehouse, shopping center, library and so on.



Single shear lifting platform



Scissor lift platform



Fixed boarding bridge



Double shear (horizontal) lifting platform



Dust single lifting platform

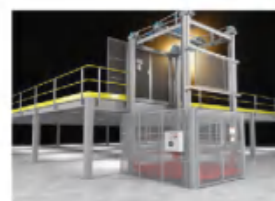

Four-post freight elevator



Double shear (vertical) lifting platform



Mechanical freight elevator



Car lifting platform



Hydraulic freight elevator



Mobile boarding bridge

Operation panel series



CMP-01
(Standard)



CMCB-01
(Standard)



CMCB-01A
(Optional)



CMP-04
(Optional)



CMP-02
(Optional)



CMCB-02
(Optional)



CMCB-02B
(Optional)



CMP-05
(Optional)
Disable person COP

Optional button



AN-01



AN-02



AN-03



AN-04



AN-05



AN-11



AN-06



AN-07



AN-08



AN-09



AN-10



CMP-03
(Optional)



CMCB-03
(Optional)



CMCB-03A
(Optional)

Horizontal display



CMZH-01
(Optional)



CMZH-02
(Optional)



CMZH-03
(Optional)

Optional display screen



CMD-01
7 inch display
(Optional)



CMD-02
8 inch display
(Optional)



CMD-03
10 inch display
(Optional)

CMP-06
Optional

Integrated operation panel



Whole series of
card reader



Fingerprint sensor



IC access card

Landing door series



CMLD-001 Standard **CMLD-002** Optional **CMLD-003** Optional
 Hairline stainless steel Stainless steel, glass Mirror, etched and hairline



CMLD-004 Optional **CMLD-005** Optional **CMLD-006** Optional
 Mirror, etched Mirror, etched Mirror, etched



CMLD-007 Optional **CMLD-008** Optional **CMLD-009** Optional
 Mirror, etched Mirror, etched Mirror, etched



CMLD-010 Optional **CMLD-011** Optional **CMLD-012** Optional
 Mirror, etched Mirror, etched Black titanium, mirror and etched

Note: The decoration requirements (material, color) of the ceiling of the car hall door can be customized according to your own needs, which is almost the meaning.

Landing door series



CMLD-013 Optional **CMLD-014** Optional **CMCD-015** Optional
 Titanium, mirror and etched Black titanium, mirror and etched Black titanium, mirror and etched

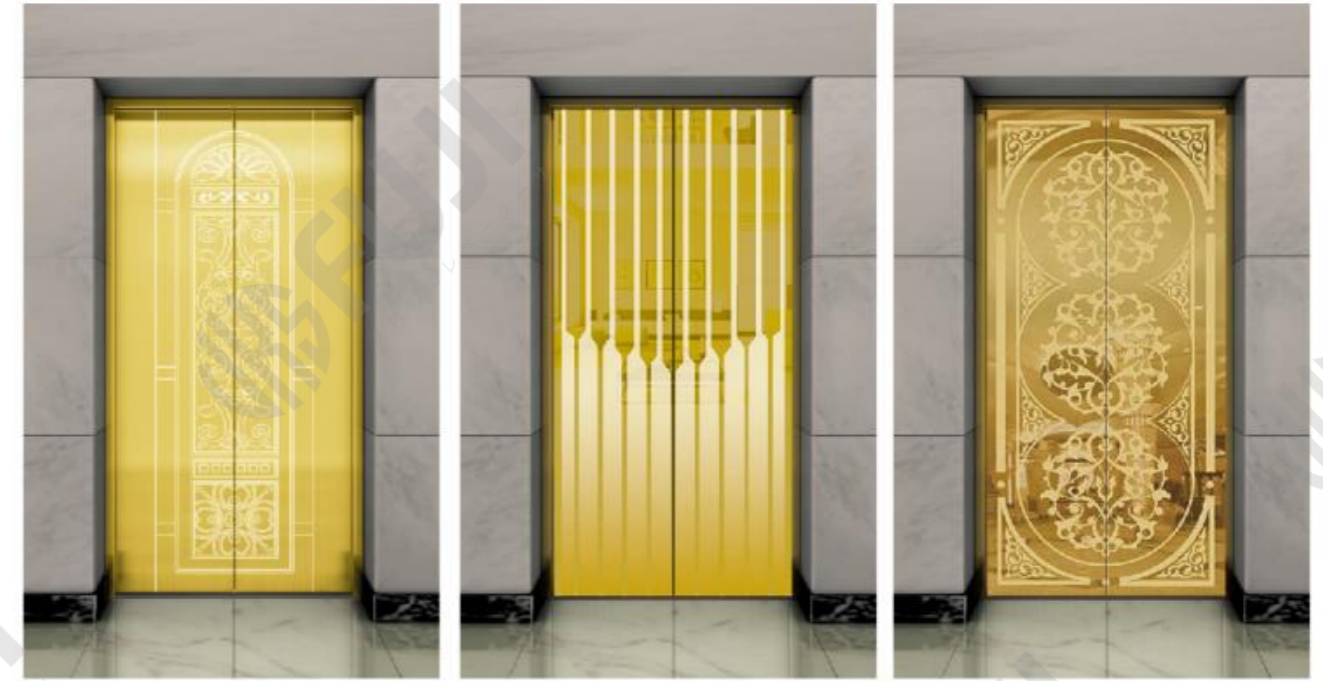

CMLD-019 Optional **CMLD-020** Optional **CMLD-021** Optional
 Titanium, mirror and etched Titanium, mirror and etched Titanium, mirror and etched



CMLD-016 Optional **CMLD-017** Optional **CMLD-018** Optional
 Rose, mirror and etched Titanium, mirror and etched Champagne gold, mirror and etched



CMLD-022 Optional **CMLD-023** Optional **CMLD-024** Optional
 Titanium, mirror and etched Titanium, mirror and etched Titanium, mirror and etched

Landing door series



CMLD-025 Optional Titanium, mirror and etched
CMLD-026 Optional Titanium, mirror and etched
CMLD-027 Optional Titanium, mirror and etched



CMLD-028 Optional Titanium, mirror and etched
CMLD-029 Optional Rose, mirror and etched
CMLD-030 Optional Titanium, stainless steel and glass

Handrail series



Ceiling series



CMC-01 Optional



CMC-06 Optional



CMC-11 Optional



CMC-16 Optional



CMC-02 Optional



CMC-07 Optional



CMC-12 Optional



CMC-17 Optional



CMC-03 Optional

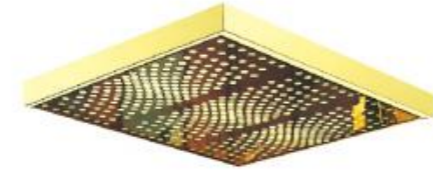

CMC-08 Optional



CMC-13 Optional



CMC-18 Optional



CMC-04 Optional



CMC-09 Optional



CMC-14 Optional

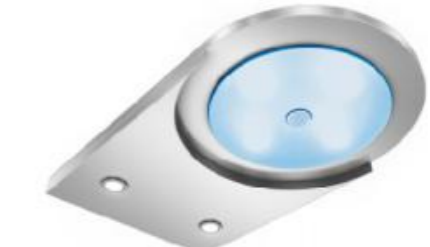

CMC-19 Optional



CMC-05 Optional



CMC-10 Optional



CMC-15 Optional



CMC-20 Optional

Floor series

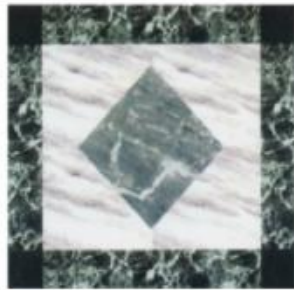

CMF-01
Optional



CMF-02
Optional



CMF-03
Optional

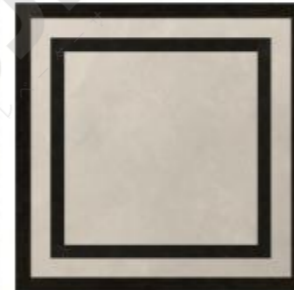

CMF-04
Optional



CMF-05
Optional



CMF-06
Optional



CMF-07
Optional

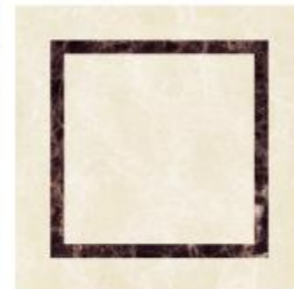

CMF-08
Optional

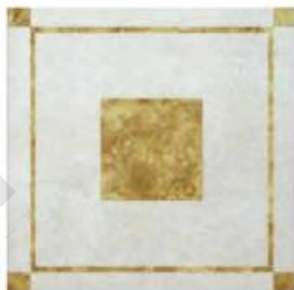

CMF-09
Optional



CMF-10
Optional



CMF-11
Optional



CMF-12
Optional



CMF-13
Optional



CMF-14
Optional



CMF-15
Optional



CMF-16
Optional



CMF-17
Optional



CMF-18
Optional



CMF-19
Optional

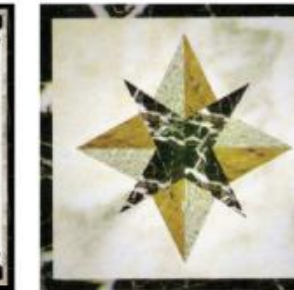

CMF-20
Optional



CMF-21
Optional



CMF-22
Optional



CMF-23
Optional



CMF-24
Optional



CMF-25
Optional



CMF-26
Optional



CMF-27
Optional



CMF-28
Optional



CMF-29
Optional



CMF-30
Optional



CMF-31
Optional



CMF-32
Optional



CMF-33
Optional



CMF-34
Optional

The pictures are plotted by computer and are likely somewhat different from the actual products.

Small machine room passenger elevator construction sketch

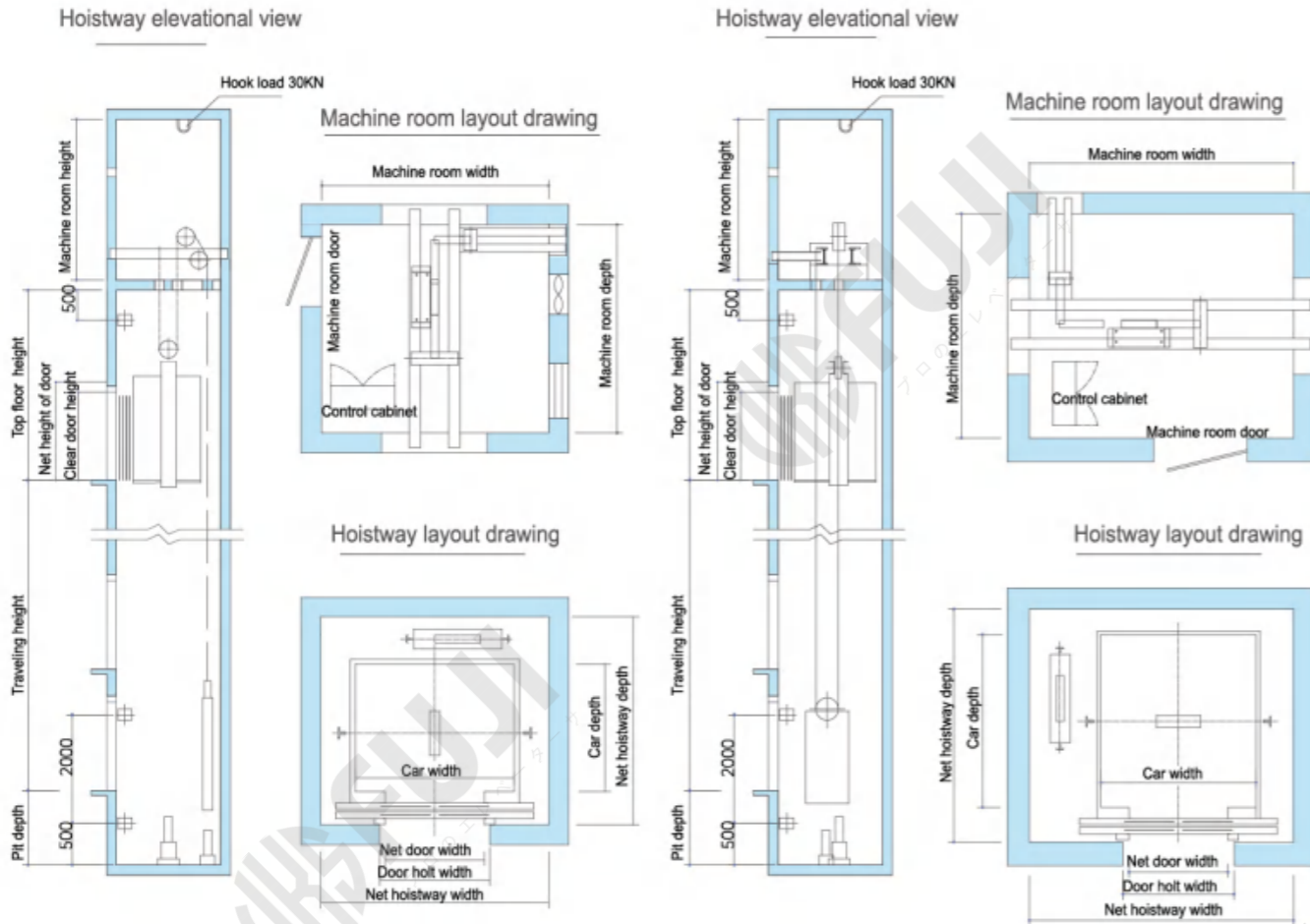

MRL passenger elevator construction sketch

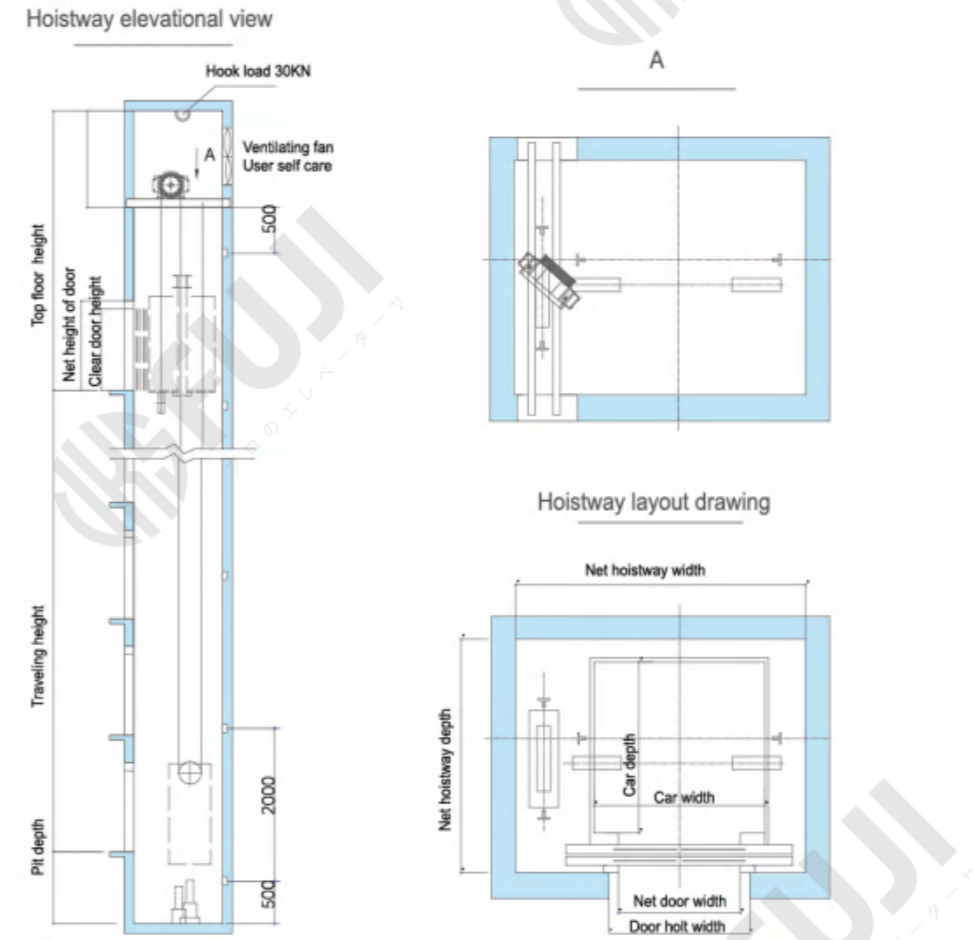

Model	Load (KG)	Passenger	Speed (m/s)	Net size of car CW×CD×CH(mm)	Net door opening size OP×OPH(mm)	Net hoistway size HW×HD(mm)	Machine room size MRW×MRD×MRH(mm)	Pit depth (mm)	Overhead height OH
AL100	450KG	6P	1.0	1100×1100×2400	700×2100	1800×1800	1800×1800×2200	1400	4200
			1.5					1500	4600
AL100	630KG	8P	1.0	1400×1100×2400	800×2100	2000×1850	2000×1850×2200	1400	4200
			1.5-1.75					1700	4500
			2.0					1400	4200
AL100	800KG	10P	1.0	1400×1350×2400	800×2100	2000×2100	2000×2100×2400	1700	4500
			1.5-1.75					1800	4800
			2.0					2200	5200
			2.5					1400	4200
			3.0					1700	4500
AL100	1000KG	13P	1.0	1600×1400×2400	900×2100	2200×2200	2200×2200×2400	1800	4800
			1.5-1.75					2200	5200
			2.0					2800	5800
			2.5					1400	4200
AL100	1150KG	15P	1.0	1900×1400×2400	1000×2100	2300×2200	2300×2200×2400	1700	4500
			1.5-1.75					1800	4800
			2.0					2200	5200
			2.5					2800	5800
			3.0					1400	4200
AL100	1250KG	16P	1.0	1900×1500×2400	1100×2100	2400×2200	2400×2200×2400	1700	4500
			1.5-1.75					1800	4800
			2.0					2200	5200
			2.5					2800	5800
AL100	1350KG	18P	1.0	1900×1600×2400	1100×2100	2600×2200	2600×2200×2400	1400	4200
			1.5-1.75					1700	4500
			2.0					1800	4800
			2.5					2200	5200
AL100	1600KG	21P	1.0	2000×1750×2400	1200×2100	2600×2450	2600×2450×2500	2800	5800
			1.5-1.75					1400	4200
			2.0					1700	4500
			2.5					1700	4500
			3.0					1400	4200
AL100	2000KG	26P	1.0	2000×2100×2400	1200×2200	2600×2900	2600×2900×2600	1700	4500
			1.5-1.75					1800	4800
			2.0					2200	5200
			2.5					2200	5200
			3.0					2800	5800

Model	Load (KG)	Passenger	Speed (m/s)	Net size of car CW×CD×CH(mm)	Net door opening size OP×OPH(mm)	Net hoistway size HW×HD(mm)	Pit depth (mm)	Overhead height OH
ALN180	450KG	6P	1.0	1100×1100×2400	700×2100	800×1500	1500	4200
			1.5-1.75				1500	4500
			2.0				2000	5000
			2.5				2500	5500
ALN180	630KG	8P	1.0	1100×1400×2400	800×2100	1800×1800	1500	4200
			1.5-1.75				1500	4500
			2.0				2000	5000
			2.5				2500	5500
ALN180	800KG	10P	1.0	1400×1350×2400	800×2100	2300×2000	1500	4200
			1.5-1.75				1500	4500
			2.0				2000	5000
			2.5				2500	5500
ALN180	1000KG	13P	1.0	1600×1400×2400	900×2100	2500×2000	1500	4200
			1.5-1.75				1500	4500
			2.0				2000	5000
			2.5				2500	5500
ALN180	1150KG	15P	1.0	1900×1400×2400	1000×2100	2800×2000	1500	4300
			1.5-1.75				1500	4600
			2.0				2000	5000
			2.5				2500	5500
ALN180	1250KG	16P	1.0	1900×1500×2400	1100×2100	2900×2000	1500	4300
			1.5-1.75				1500	4600
			2.0				2000	5000
			2.5				2500	5500
ALN180	1350KG	18P	1.0	1900×1600×2400	1100×2100	2900×2400	1500	4300
			1.5-1.75				1500	4600
			2.0				2000	5000
			2.5				2500	5500
ALN180	1600KG	21P	1.0	2000×1750×2400	1200×2100	3000×2400	1500	4300
			1.5-1.75				1500	4600
			2.0				2000	5000
			2.5				2500	5500
ALN180	2000KG	26P	1.0	2000×2100×2400	1200×2200	3400×2900	1500	4300
			1.5-1.75				1500	4600
			2.0				2000	5000
			2.5				2500	5500

MR observation elevator construction sketch

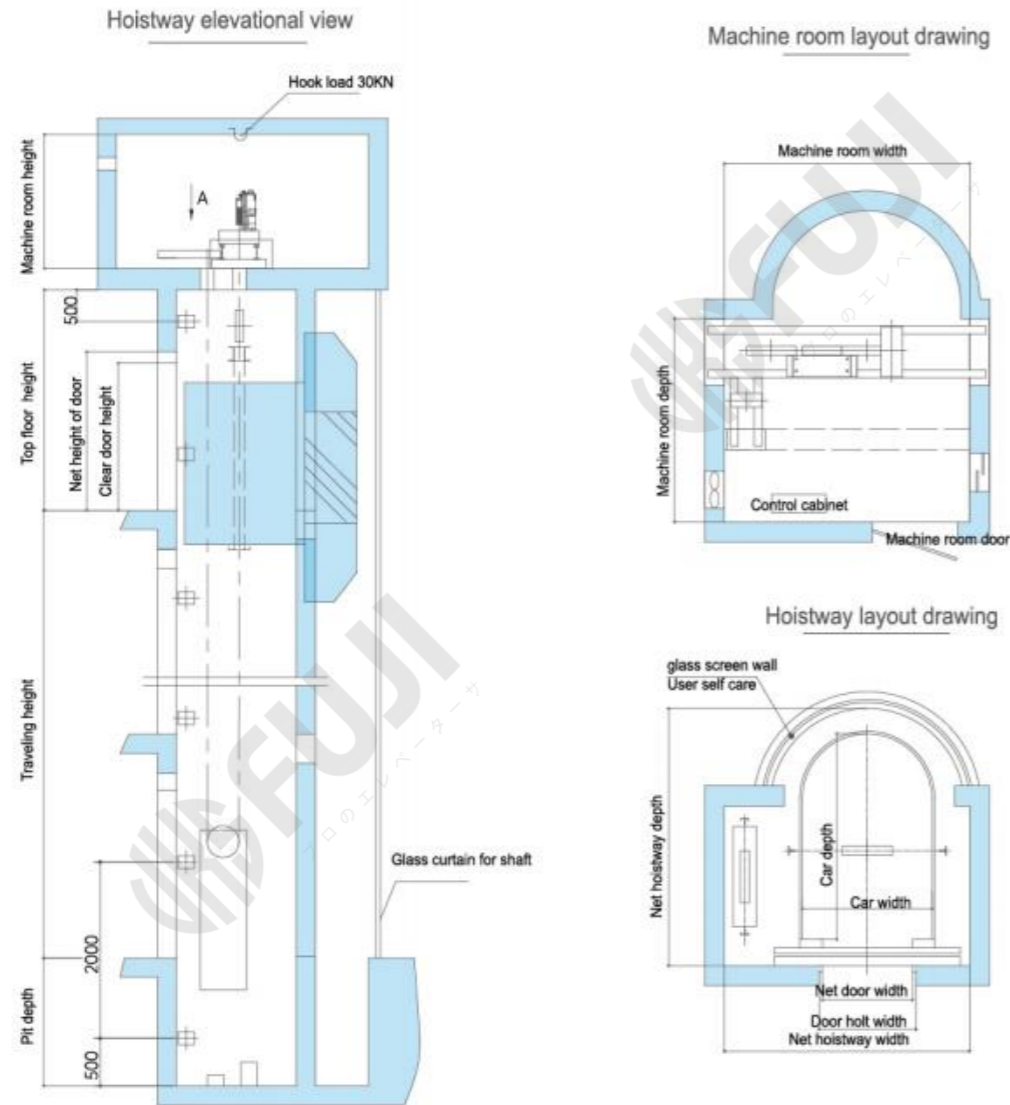

MRL observation elevator construction sketch

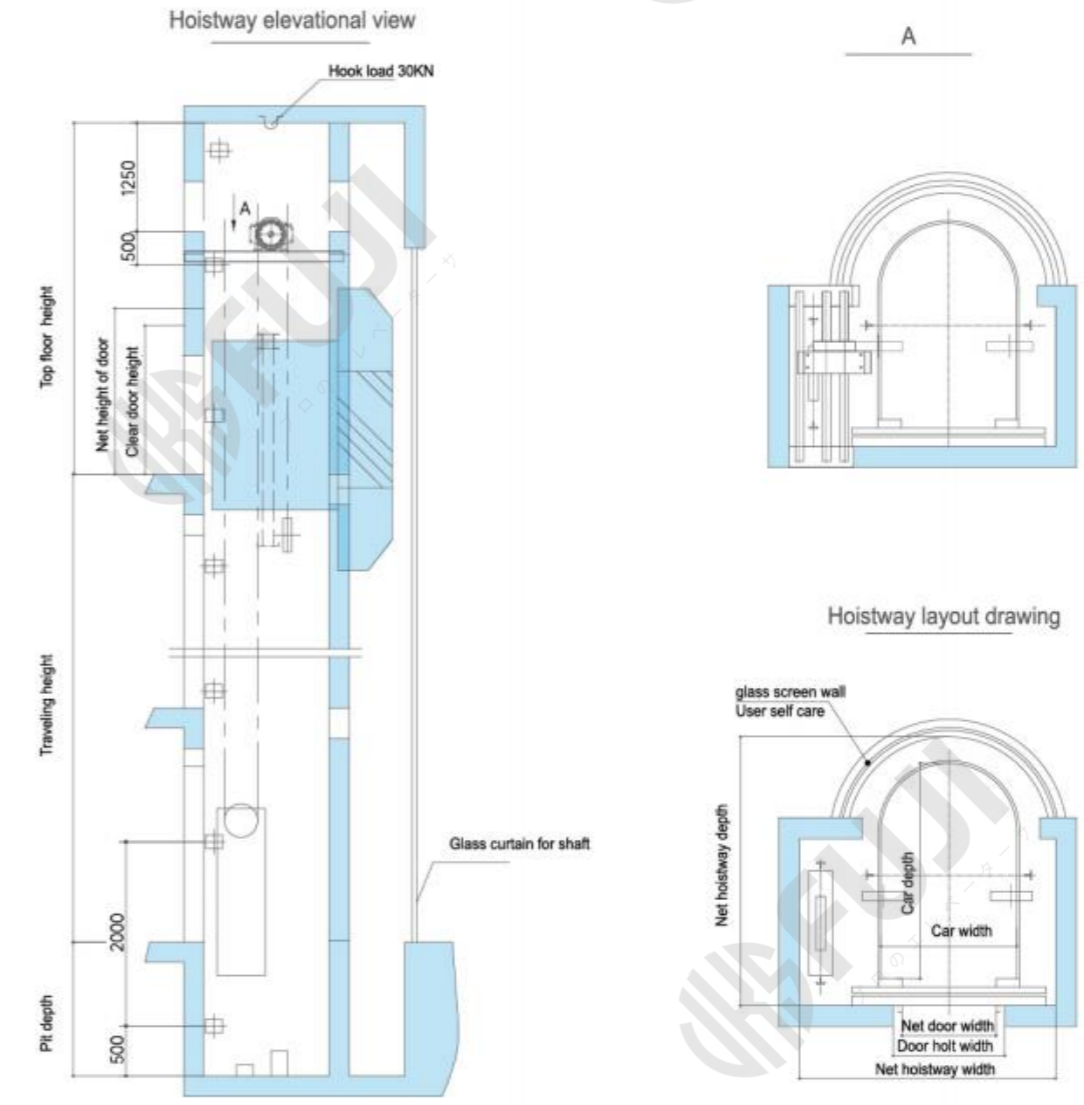

Model	Load (KG)	Passenger	Speed (m/s)	Net size of car CW×CD×CH(mm)	Net door opening size OP×OPH(mm)	Net hoistway size HW×HD(mm)	Machine room size MRW×MRD×MRH(mm)	Pit depth (mm)	Overhead height OH
AL200	450KG	6P	1.0 1.5-1.75	1100×1300×2400	700×2100	1900×1900	1900×1900×2200	1500	4500
AL200	630KG	8P	1.0 1.5-1.75	1200×1600×2400	800×2100	2000×2200	2000×2200×2200	1800	5000
AL200	800KG	10P	1.0 1.5-1.75 2.0-2.5	1400×1600×2400	800×2100	2200×2200	2200×2200×2400	2000	5000
AL200	1000KG	13P	1.0 1.5-1.75 2.0-2.5	1400×1800×2400	900×2100	2200×2400	2200×2400×2400	2000	5000
AL200	1150KG	15P	1.0 1.5-1.75 2.0-2.5	1400×2000×2400	900×2100	2200×2600	2200×2600×2400	2000	5000
AL200	1250KG	16P	1.0 1.5-1.75 2.0-2.5	1500×2000×2400	1000×2100	2300×2650	2300×2650×2400	2000	5000
AL200	1350KG	18P	1.0 1.5-1.75 2.0-2.5	1600×2100×2400	1100×2100	2400×2750	2400×2750×2400	2200	5000
AL200	1600KG	21P	1.0 1.5-1.75 2.0-2.5	1600×2300×2400	1100×2100	2500×2950	2500×2950×2400	2300	5000
AL200	2000KG	26P	1.0 1.5-1.75 2.0-2.5	1800×2500×2400	1200×2100	2800×3150	2800×3150×2400	2300	5000

Model	Load (KG)	Passenger	Speed (m/s)	Net size of car CW×CD×CH(mm)	Net door opening size OP×OPH(mm)	Net hoistway size HW×HD(mm)	Pit depth (mm)	Overhead height OH
ALN220	450KG	6P	1.0 1.5-1.75	1100×1300×2400	700×2100	1950×1900	1500	4500
ALN220	630KG	8P	1.0 1.5-1.75	1200×1600×2400	800×2100	2300×2200	1800 1800	4500 4800
ALN220	800KG	10P	1.0 1.5-1.75 2.0-2.5	1400×1600×2400	800×2100	2400×2200	1800 1800 2800	4500 4800 5800
ALN220	1000KG	13P	1.0 1.5-1.75 2.0-2.5	1400×1800×2400	900×2100	2450×2400	1800 1800 2800	4500 4800 5800
ALN220	1150KG	15P	1.0 1.5-1.75 2.0-2.5	1400×2000×2400	900×2100	2450×2600	1800 1800 2800	4500 4800 5800
ALN220	1250KG	16P	1.0 1.5-1.75 2.0-2.5	1500×2000×2400	1000×2100	2600×2650	1800 1800 2800	4600 4900 5800
ALN220	1350KG	18P	1.0 1.5-1.75 2.0-2.5	1600×2200×2400	1100×2100	2700×2850	1800 1800 2800	4600 5100 5800
ALN220	1600KG	21P	1.0 1.5-1.75 2.0-2.5	1600×2300×2400	1100×2100	2700×2650	1800 1800 2800	4600 5100 5800
ALN220	2000KG	23P	1.0 1.5-1.75 2.0-2.5	1800×2500×2400	1200×2100	2900×3150	1800 1800 2800	4600 5100 5800

MR freight elevator construction sketch

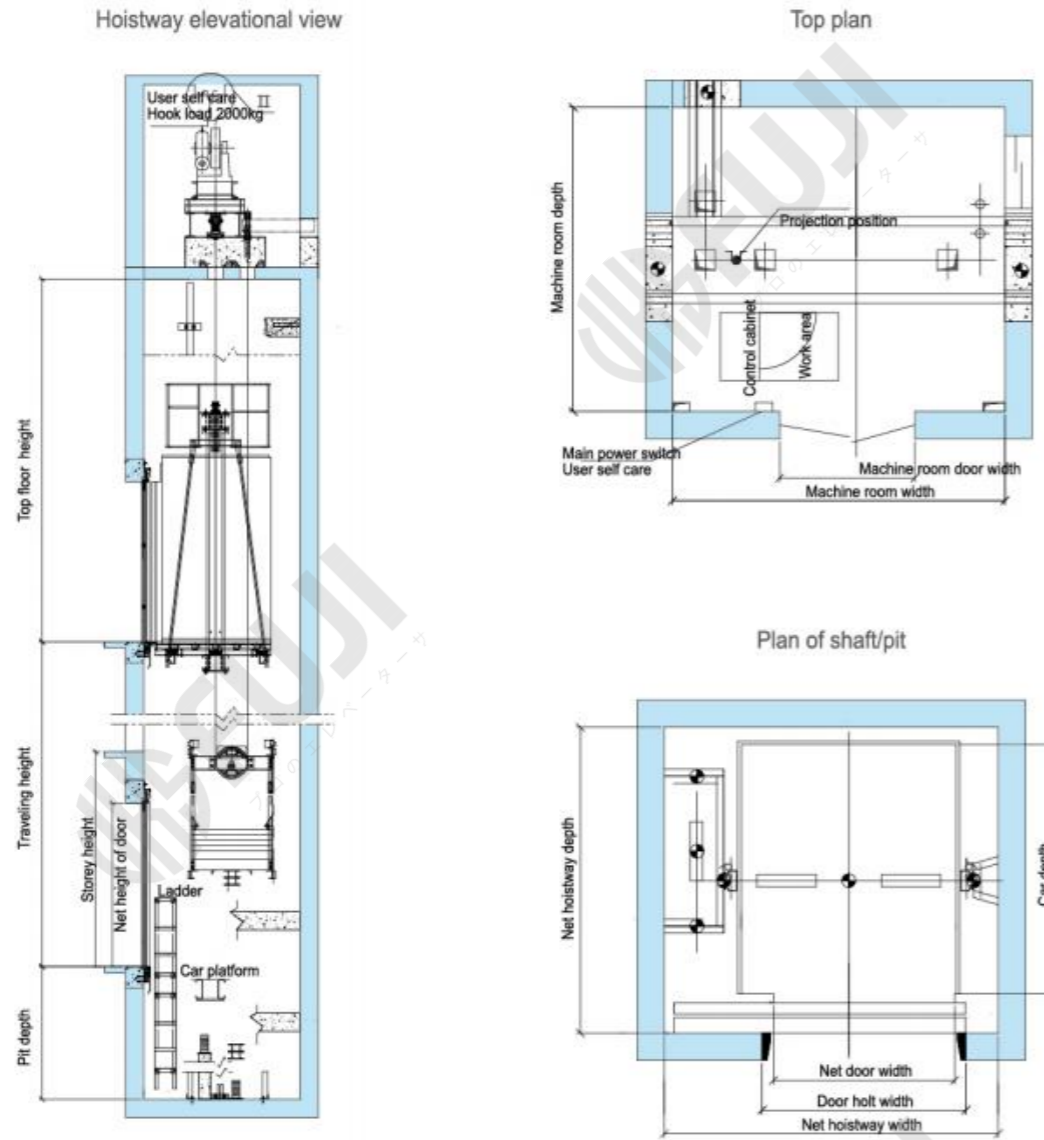

MRL freight elevator construction sketch

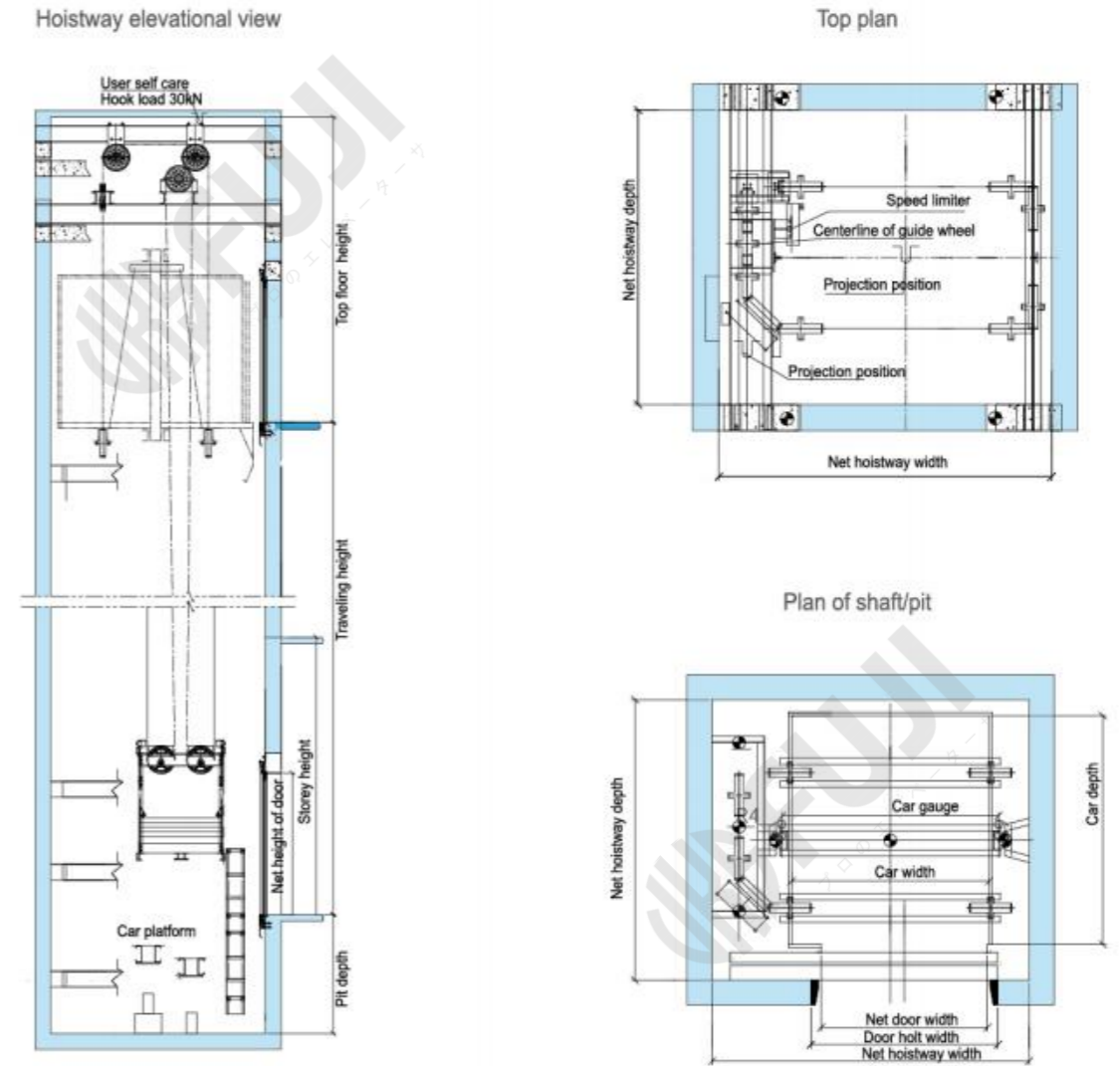

Model	Load (KG)	Speed (m/s)	Net size of car CW×CD×CH(mm)	Net door opening size OP×OPH(mm)	Net hoistway size HW×HD(mm)	Machine room size MRW×MRD×MRH(mm)	Pit depth (mm)	Overhead height OH
AL300	1600KG	0.5	1600×2200×2200	1300×2100	2500×2700	2500×2700×2500	1400	4200
		1.0						
AL300	2000KG	0.5	1600×2600×2200	1300×2100	2500×3200	2500×3200×2500	1400	4200
		1.0	1900×2200×2200	1500×2100	2800×2700	2800×2700×2500		
AL300	3000KG	0.5	2200×2700×2200	1800×2100	3300×3200	3300×3200×2500	1700	4500
		1.0						
AL300	4000KG	0.5	2400×3000×2200	1900×2100	3800×3500	3850×3850×2600	1700	4800
		1.0						
AL300	5000KG	0.25	2400×3600×2300	2000×2200	3800×4200	3800×4200×2600	1700	4500
		0.5	2800×3200×2500	2400×2400	4200×3700	4200×3700×2600		
AL300	8000KG	0.25/0.5	3000×4500×2500	2600×2400	4500×5000	4500×5000×3000	1800	5200
AL300	10000KG	0.25/0.5	3400×4500×2500	2600×2400	5000×5600	5000×5600×3000	1800	5500

Model	Load (KG)	Speed (m/s)	Net size of car CW×CD×CH(mm)	Net door opening size OP×OPH(mm)	Net hoistway size HW×HD(mm)	Pit depth (mm)	Overhead height OH
ALN330	1600KG	0.5	1300×2000×2200	1000×2100	3000×2800	1700	4500
		1.0					
ALN330	2000KG	0.5	1900×2200×2200	1500×2100	3300×2800	1700	4500
		1.0					
ALN330	3000KG	0.5	2200×2700×2200	1800×2100	3700×3200	1700	4800
		1.0					
ALN330	4000KG	0.5	2200×3250×2200	1900×2100	3850×3850	1700	5200
		1.0					
ALN330	5000KG	0.25	2400×3600×2500	2000×2400	4100×4100	1800	5500
		0.5					

MR hospital elevator construction sketch

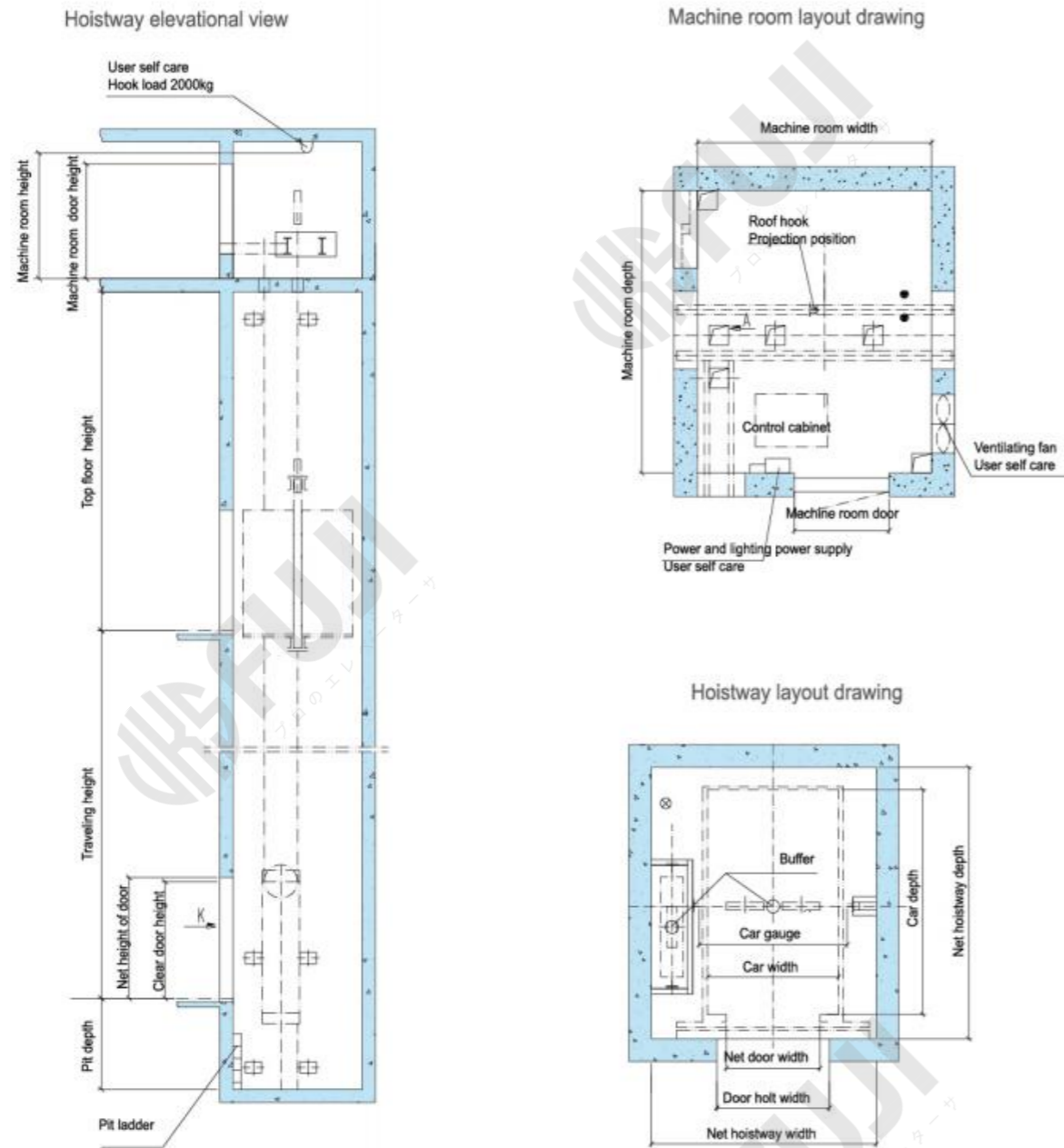

Model	Load (KG)	Passenger	Speed (m/s)	Net size of car CW×CD×CH(mm)	Net door opening size OP×OPH(mm)	Net hoistway size HW×HD(mm)	Machine room size MRW×MRD×MRH(mm)	Pit depth (mm)	Overhead height OH
AL500	1600KG	21P	1.0	1400×2400×2400	1200×2100	2300×2850	2300×2850×2500	1500	4400
			1.5-1.75					1700	4500
			2.0					1800	4600
AL500	2000KG	26P	1.0	1600×2550×2400	1300×2100	2600×3000	2600×3000×2600	1500	4400
			1.5-1.75					1700	4500
			2.0					1800	4600

MRL hospital elevator construction sketch

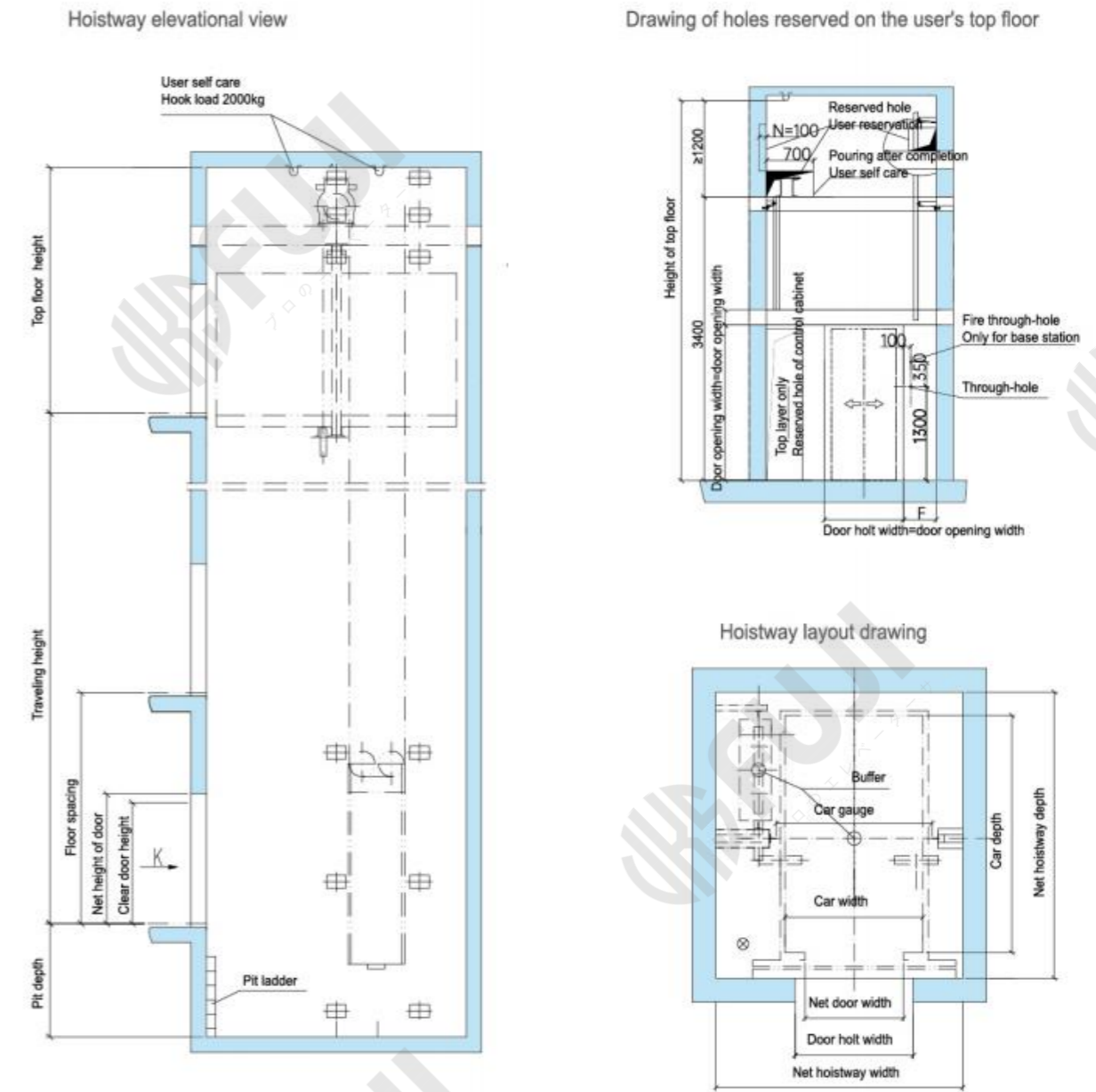

Model	Load (KG)	Passenger	Speed (m/s)	Net size of car CW×CD×CH(mm)	Net door opening size OP×OPH(mm)	Net hoistway size HW×HD(mm)	Pit depth (mm)	Overhead height OH
ALN550	1600KG	21P	1.0	1400×2400×2400	1200×2100	2550×2850	1600	4500
			1.5-1.75				1800	4800
			2.0				2000	5000
ALN550	2000KG	26P	1.0	1600×2600×2400	1300×2100	2750×3050	1600	4500
			1.5-1.75				1800	4800
			2.0				2000	5000

Shaft solution plan

Features of steel structure shaft frame

Independent frame glass design has no extra increase of the building cost with fine light transparency. It integrates with indoor decoration into one. Installation position can be chosen by the user. It resists any corrosion with long service life. It chooses industrial-level aluminum alloy. Glass applies safety laminated glass.

Features of aluminum alloy shaft frame

High cost performance: in later period, skin plating gets harmonious design style with packaging (enclosure) by decoration unit. Installation position can be chosen by the user. It goes through painted anti-rusting treatment in the surface. It resists any corrosion too.

High grade painted steel frame



High grade painted aluminum alloy frame



Steel structure shaft frame



Aluminum alloy shaft frame



Aluminum alloy section



Section of steel structure

Professional and considerate services



Serving vast customers is our only objective. We assume that the core of service does not lie in the process, but the very result. We are not only required the extensive sales of our elevators. We also demand 100% satisfaction from our clients. Our company is engaged in enhancing the personnel's skill and quality. We strive to well-settle the service efficiency and quality. Therefore the clients can truly experience our superior and professional services. The clients of our company can get the global high quality, high standard and the professional services. All-year-round 8760-hour safeguard just for your word of "I am satisfied with it!"

- It sets multiple service net points all over the country, it fulfills same prompt and nearby repair & maintenance.
- It ensures the excellent installation quality through the certified installation team, effective and standard installation flow.
- Aiming at the customers' requirements, it scientifically and rationally tailor-makes the repair & maintenance plans.
- Customer service center offers 24-hour advisory service with quick response.
- Real-time long-distance monitor is based upon Web of Things technology with quick diagnosis. After that, repair and maintenance staff quickly goes to your doorstep.



Professional maintenance



Service line



Professional team



Convenient service