



## *Stair elevator*

Let the elderly at home easily go up and down the stairs

Zhejiang Aoma Elevator Co.,Ltd

Add:No.2555,Qianghua Road,Nanxun Economic Development Zone,  
Huzhou,Zhejiang,China

Tel:+86-0572-3636576

Email:cyma@vksfujilift.com

Website:www.vksfujilift.com



# Stairlift Elevator

## Intellectual straight-rail stair chair lift

Stair chair lift can help the old / disabled to independently up / down the stairs. It solves the problem of difficult up / down with convenient installation. It operates along the rail left / right of the stairs. It does not destroy any family facilities. It is especially suitable for decorated houses. Stair chair lift applies combination of steel structure, aluminum alloy casting and combustible plastic housing with safe and reliable properties, popular and attractive outline.

## Intellectual auxiliary hoist intellectual hoist electric balancing device

Excellent design of intellectual hoist Ai system ensures that operator is in the correct ergonomics position. Meanwhile, it can fully control the load. Control handle is equipped with programming software. It can be tailor-made according to the clients' application requirements. Linear instinct induced handle controls the intellectual hoist servo system. Therefore it can train less operators. Handle is reacted by instant touch. Hold and operate it to move the load.



## Curved Stair Lift

- ❖ A new design concept from the UK
- ❖ The latest control technology in the whole industry
- ❖ Double-tube steel rail, track angle 0-52 degrees
- ❖ Armrests, leather cushions, and footrests are fordable design
- ❖ All new swivel seat design
- ❖ Ergonomic control lever design
- ❖ Electronic self-locking seat belt
- ❖ Seven-layer safety protection system for the whole machine
- ❖ LCD status and diagnostic display
- ❖ Sensitive safety sensor
- ❖ Over-speed safety protection system
- ❖ Intelligent call service system
- ❖ Built-in battery management system
- ❖ Set up multiple charging piles
- ❖ Electric foot pedal optional
- ❖ Maximum load of standard model 120KG
- ❖ The maximum load of the heavier model is 160KG

# Double track curved stairlift



● Swivel seat



● Fordable armrest



● Switch control paddle



● Diagnosis display screen



● Key switch



● Electronic self-locking seat belt

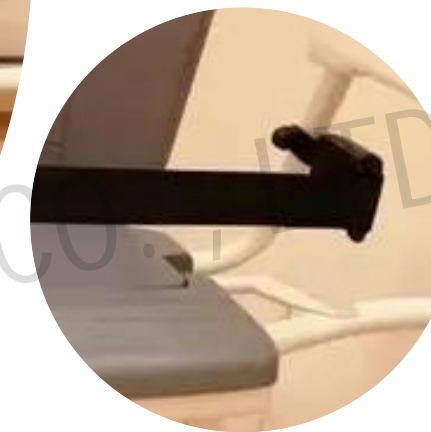

● Sensitive safety sensing device



● Main power switch



● Folding foot pedal



● Double-tube Steel rail

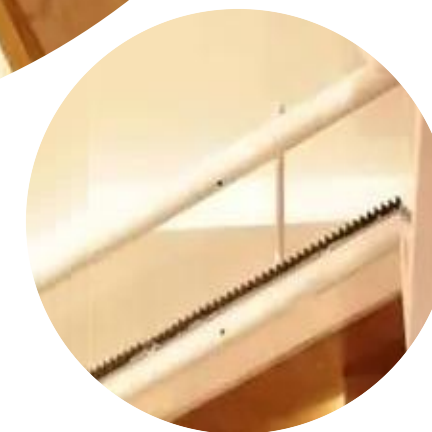

## Picture of leather linear stair lift

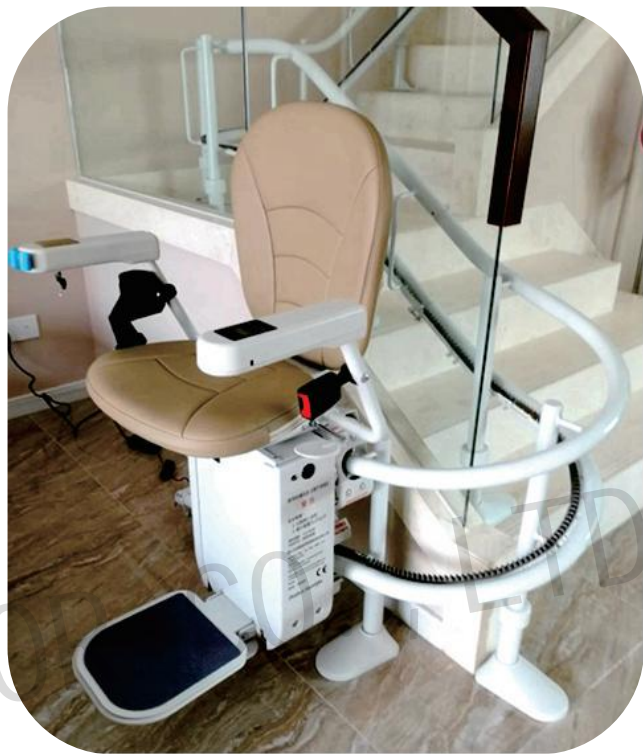

## Overspeed safety protection system

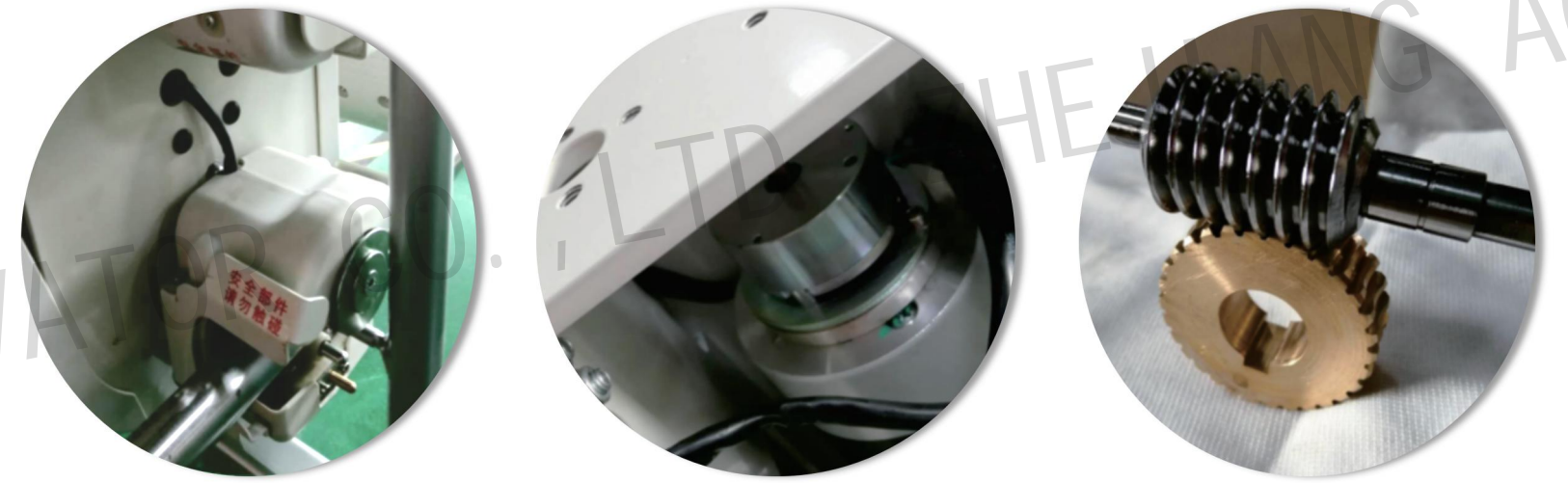

During the operation of the Aoma stairlift, if the running speed exceeds the safe speed set by the system, the whole machine will immediately cut off the power supply to stop running and mechanically brake to ensure absolute safety. In this case, please contact our after-sales service engineer to check and repair for you. Maintain it to return to normal use.

## Intelligent call service system

Aoma stairlift remote control system. In the case of inching function, colleagues have also added linkage function. Users can freely choose according to their needs. The remote control can control the stairlift to move up or down automatically. The operation is simple and convenient.

### Leather type curved stairlift size chart

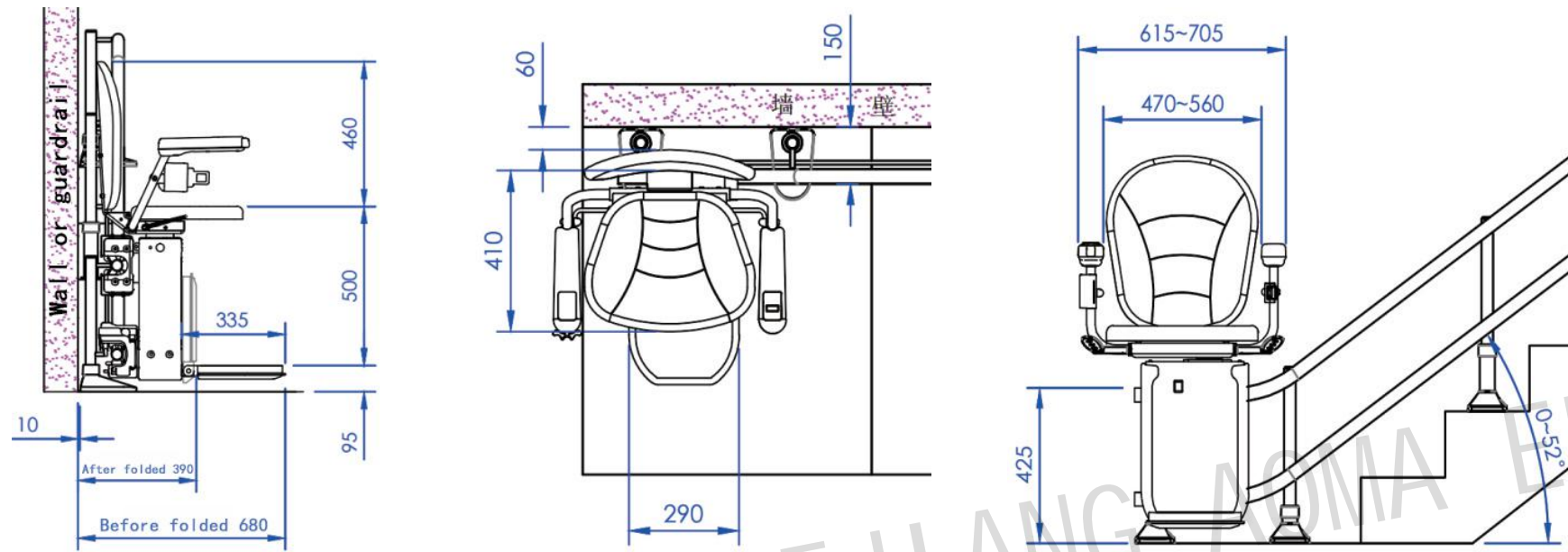

### Sensitive safety sensing device



There are 14 safety switches on the pedal and both sides of the chassis. During the operation of the stairlift, when obstacles are encountered on the edge of the pedal and on both sides of the chassis, they can respond sensitively and stop safely. After the obstacles are clear, restart it to recover. Normal operation guarantees the absolute safety of your use process.

### Schematic diagram of installation in various positions of curved stairlift

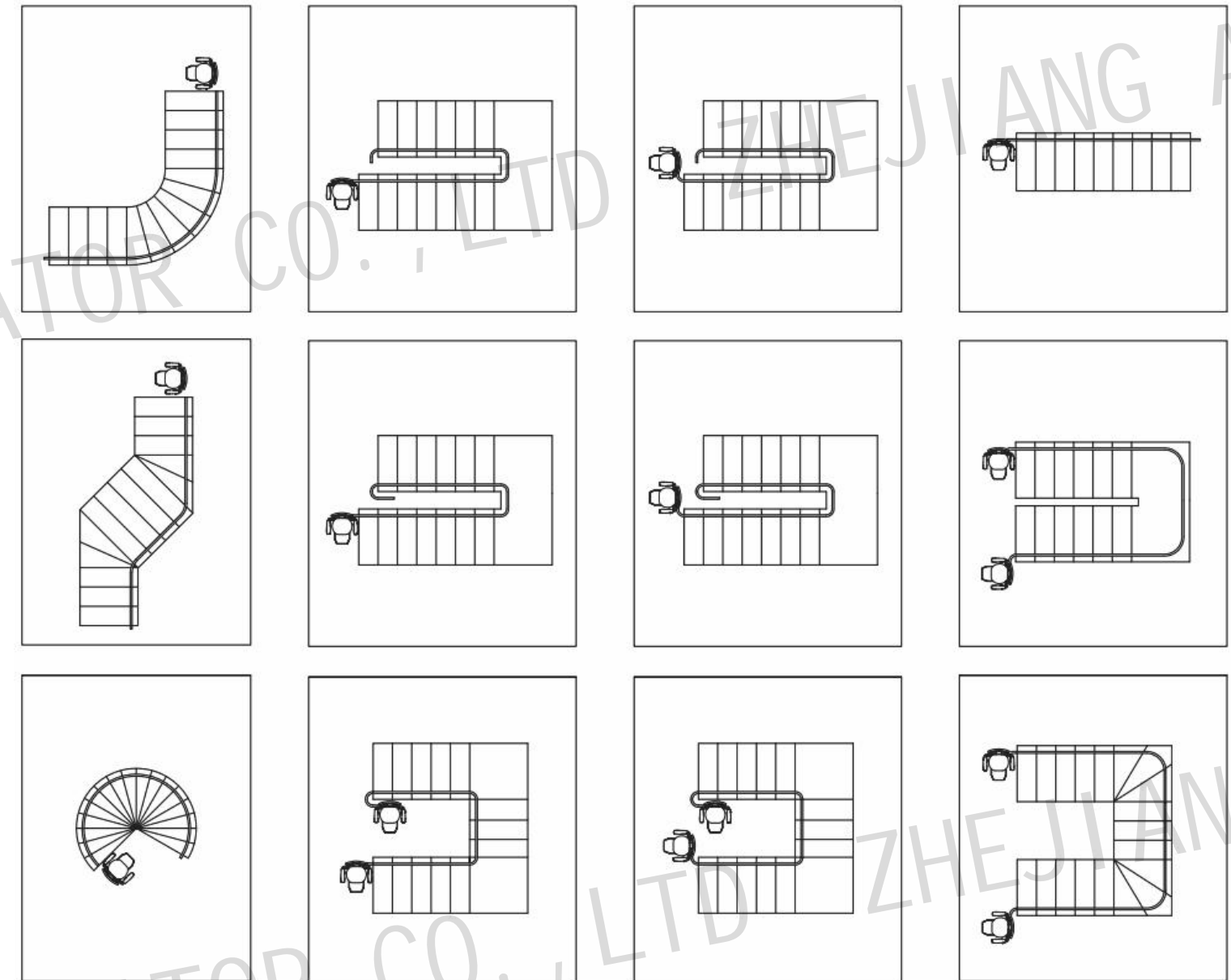

### Standard color of curved track



**Milky white**

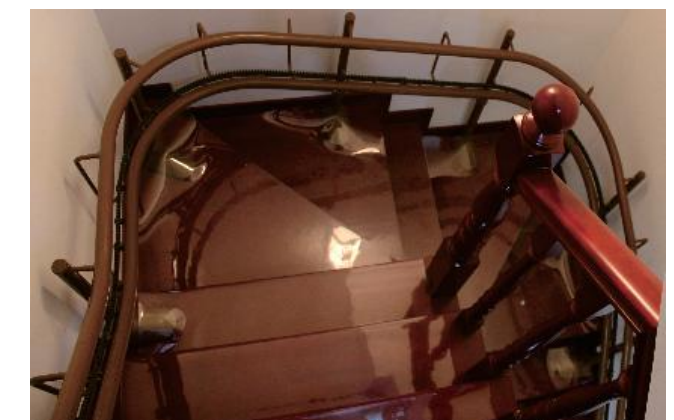

**Deer brown**

### PU type curved stairlift size chart

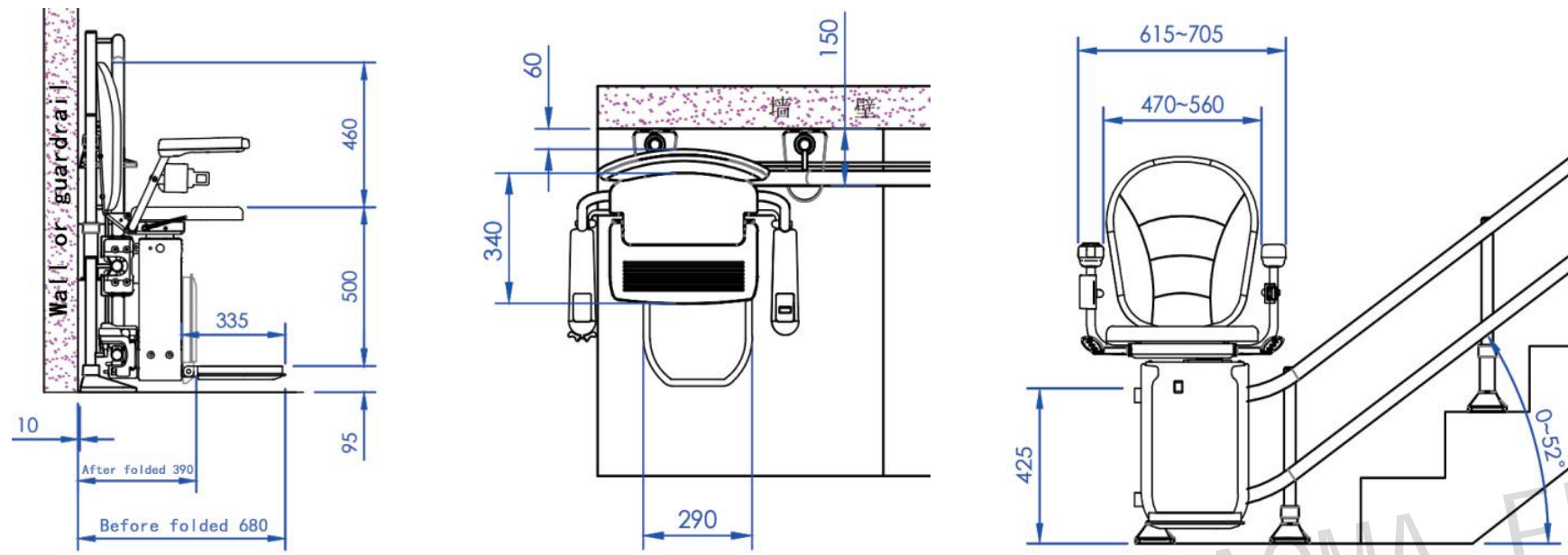

### Leather type linear stairlift

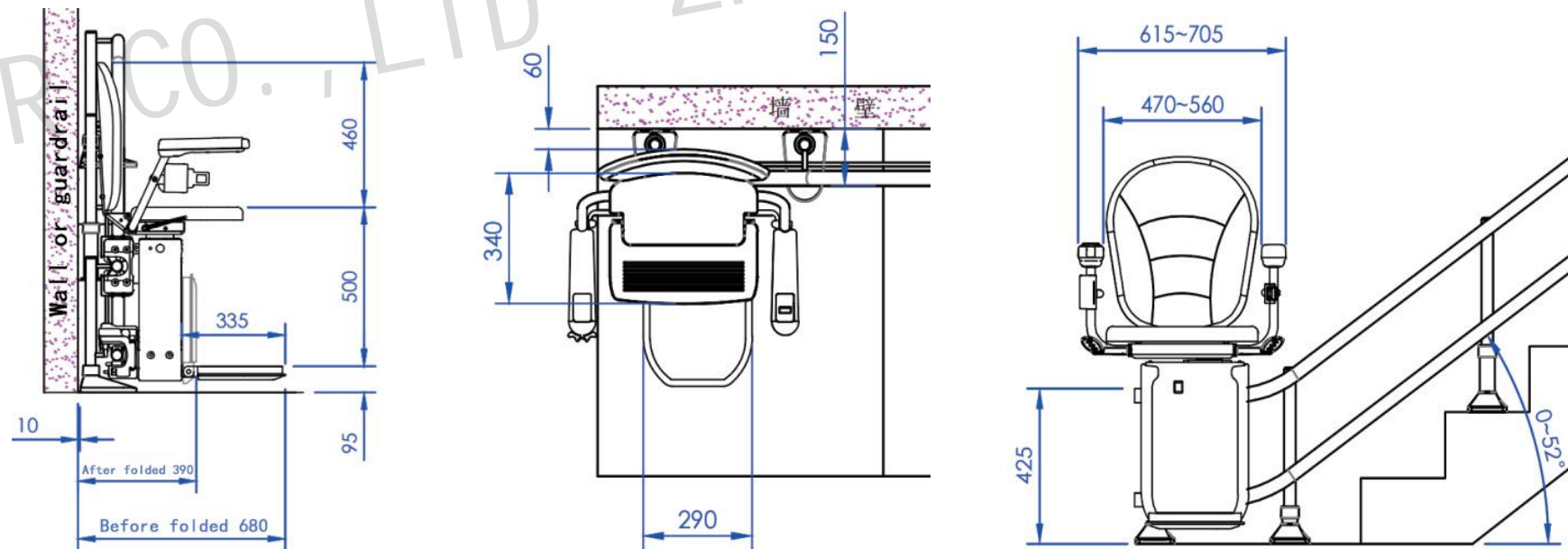

Before installation, the stairlift was surveyed by a professional engineer and measured with a 3D photogrammetric system. The dimensions were accurate.

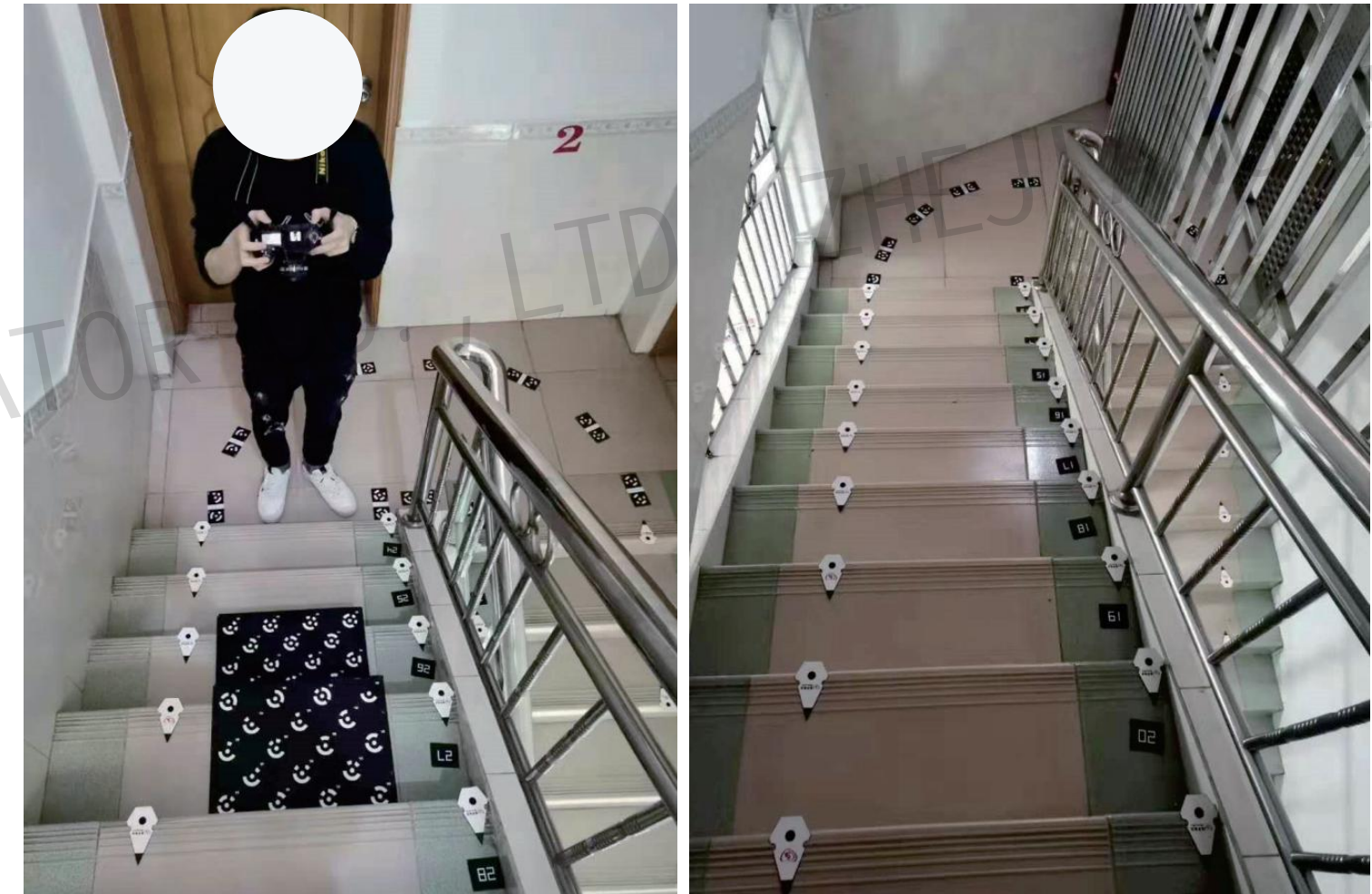

Aoma stairlift are carefully designed and tailored according to the data of the 3D photogrammetric system. Each customer has a unique design plan. After the plan makes the customer satisfied, the production will start.

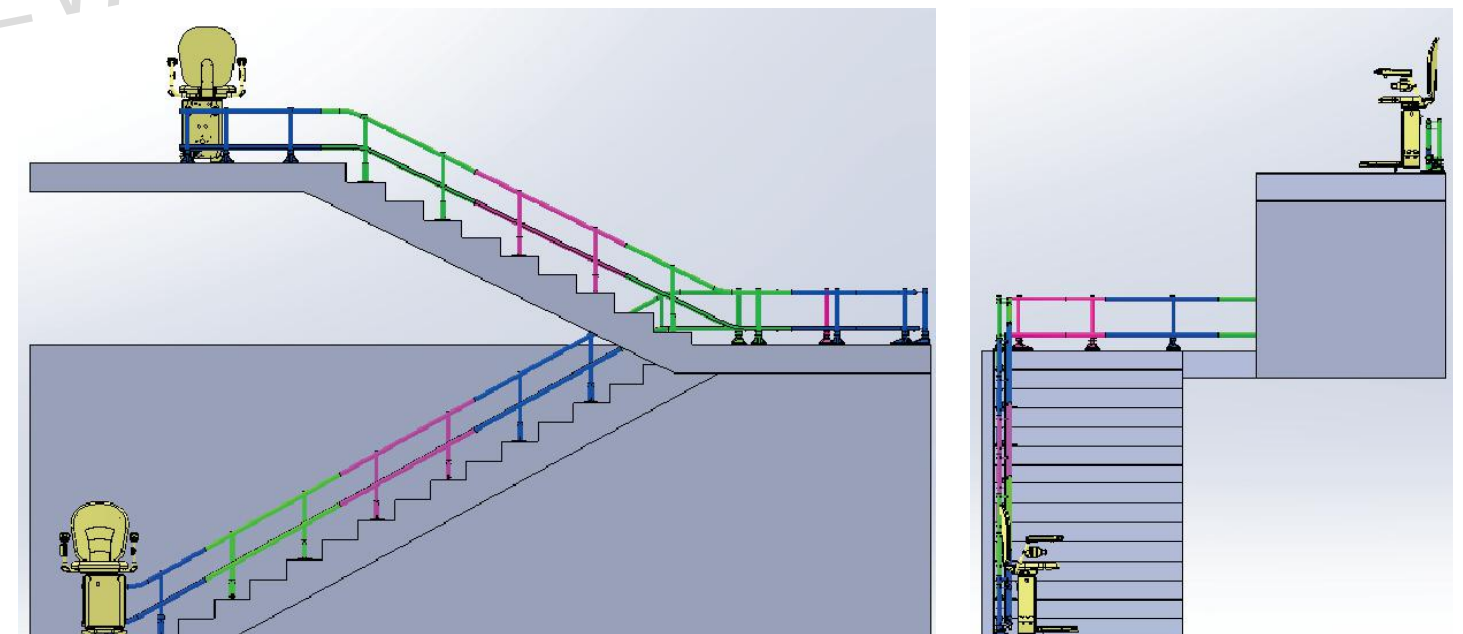
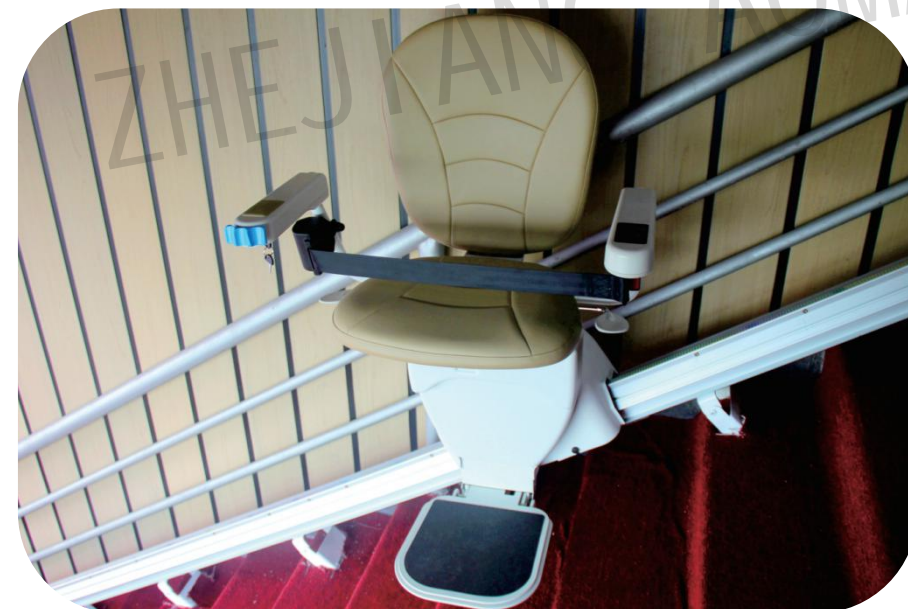
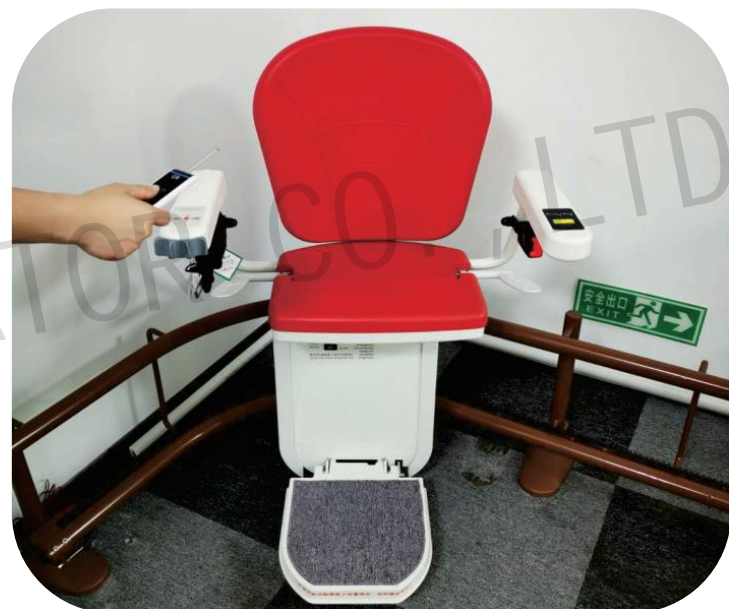

# Measurement methods

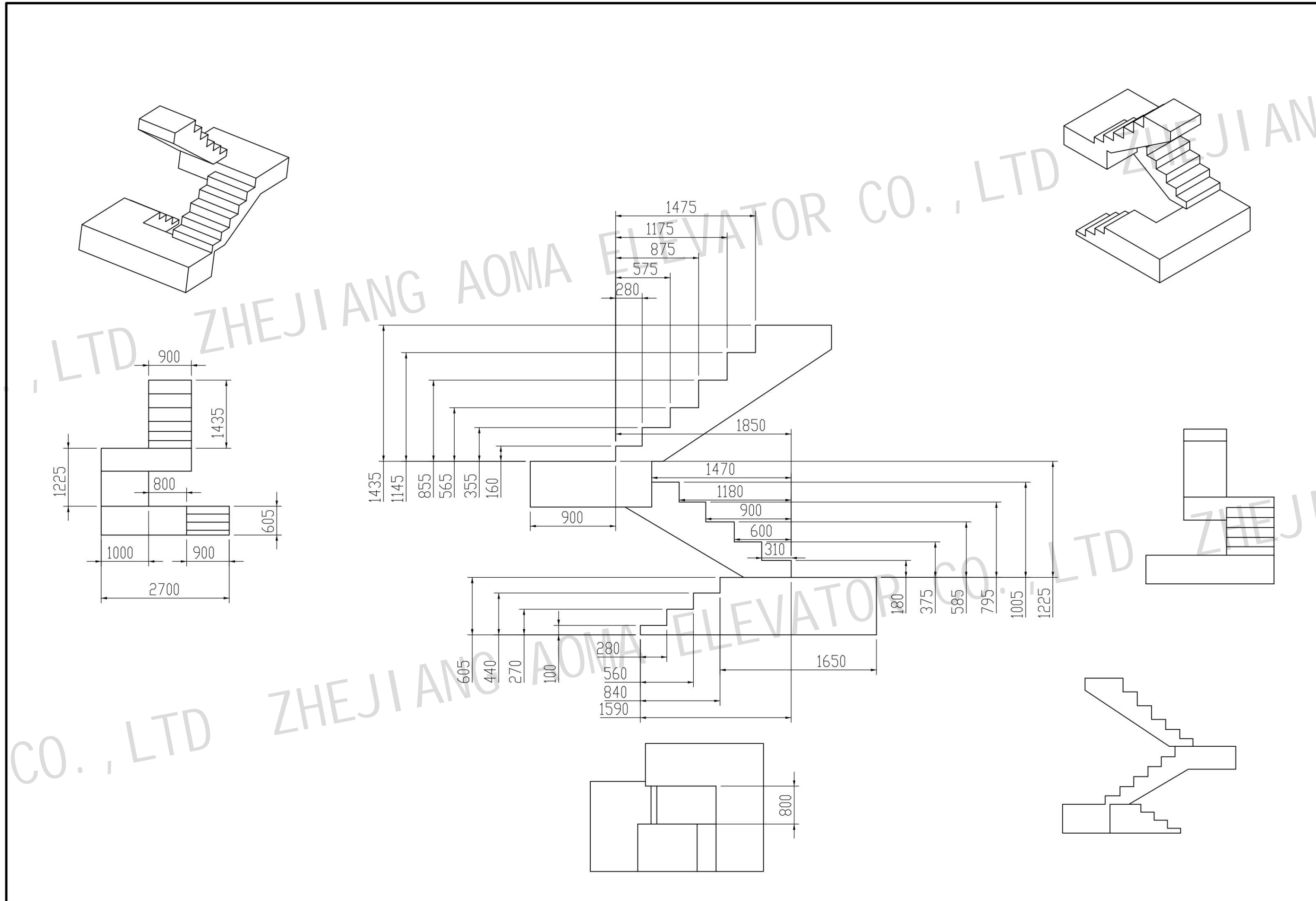



## LED status and diagnostic display



The LCD display screen displays the running status and fault code of the stairlift in real time. If you encounter a problem during operation, you can refer to the user manual for diagnosis and solution based on the code on the LCD display.

Common problems can be diagnosed by themselves and normal operation can be resumed. There no need to contact an after-sales service engineer.



## Leather seat back cushion standard color



Blue

Red

Beige

## PU seat back cushion standard color





Deep blue

Oriental Red

Telecom Gray

A variety of seat back cushion styles and colors are available. If you have special requirements, we can customize it according to your preferences and needs.

## Main parameter table of Aoma stair elevator

<b>Product name</b>	Leather curved stair lift	PU Curved Stair Elevator	Leather linear seat elevator
<b>Product model</b>	Aoma-C88	Aoma-C89	Aoma-S188
<b>Product picture</b>			
<b>Charging method</b>	Automatic charging at both ends of the track, which can increase the middle charging position	Automatic charging at both ends of the track, which can increase the middle charging position	Automatic charging at both ends of the track
<b>Foot pedal</b>	Manual (standard) Electric (optional)	Manual (standard) Electric (optional)	Manual (standard)
<b>Seat back cushion</b>	PVC fabric, three colors are available	PU process, three colors are available	PVC fabric, three colors are available
<b>Track material</b>	φ 38×T3mm Steel pipe	φ 38×T3mm Steel pipe	High-strength aluminum alloy
<b>Track surface treatment</b>	Electrostatic spraying, two colors are available	Electrostatic spraying, two colors are available	Silver matte anodized
<b>Orbit angle</b>	0° -52°	0° -52°	25° -55°
<b>Standard maximum load</b>	120KG	120KG	120KG
<b>Maximum load for heavier models</b>	160KG	160KG	140KG

<b>Transfer method</b>	Rack and pinion (Add lubricating grease)
<b>Driver</b>	DC motor drive
<b>Motor Power</b>	350W
<b>Use Voltage/Current</b>	24V / 0-18A
<b>Charging Voltage/Current</b>	100-240v/ 1.2A
<b>Energy consumption</b>	About 0.014kwh
<b>Battery</b>	12V9Ah *2 (Lead-acid batteries)
<b>Speed</b>	0.12m/s
<b>Armrest LCD display</b>	Display running status and fault code
<b>Seat</b>	Rotatable seat
<b>Rack tooth width</b>	10mm
<b>Way over the line</b>	Threading inside the track
<b>Fixed way</b>	Screw fixed to the ground



## Hydraulic stair wheelchair lift

- ❖ The barrier-free lift is a lift specially designed and manufactured for the disabled. In order to facilitate the travel and sightseeing of the disabled, in communities, hospitals, schools, hotels, public places and other places. Barrier-free elevators are installed next to the escalator in the tourist elevator passage. The barrier-free lift can accommodate wheelchairs and vehicles. The disabled or people with limited mobility only need to press the help buttons at both ends, and the staff on duty will immediately turn on the automatic lift.
- ❖ It is a small hydraulic elevator that replaces elevators. It uses the remaining space in the corner to install on the wall, which is convenient and quick, does not occupy the area of the room, and is economical and suitable for replacing the elevator. It is suitable for two- and three-story buildings, leap-type buildings, attics, basements and other small areas. It saves the floor space of the stairs, increases the room space, uses less electricity, and has low noise. It is an ideal new product to replace the stairs. 220v voltage input and 36v low voltage output to ensure the safety of electricity use. Buttons can be installed in layers to achieve multi-point control. There are tracks and pits for customers to choose. Specifications can be flexibly designed according to the actual situation on site.

# Oblique hanging type barrier-free / Vertical barrier-free seat lifting platform



- High safety factor

Full travel anti-fall system

Power failure protection, lock immediately after power failure

- Fully automatic folding system

No need for human intervention during any deformation operation

- Hammer drive mode

Can be adapted to any arc installation scene

- Simple and convenient operation

Humanized operation and comfortable ride

- Energy saving and environmental protection

Low energy consumption during use, low maintenance cost

- Anti-collision function

The guardrail can automatically monitor the displacement and operate the exhibition hall equipment to ensure the safety of passengers

- Built-in battery

Ensure that the equipment can be folded without external power

- Emergency button

The device brakes immediately after pressing the emergency stop button in the running state

- Equipped with electromagnetic lock

The guardrail door is equipped with an electromagnetic lock, and the door can be opened after reaching a safe position

# More pictures

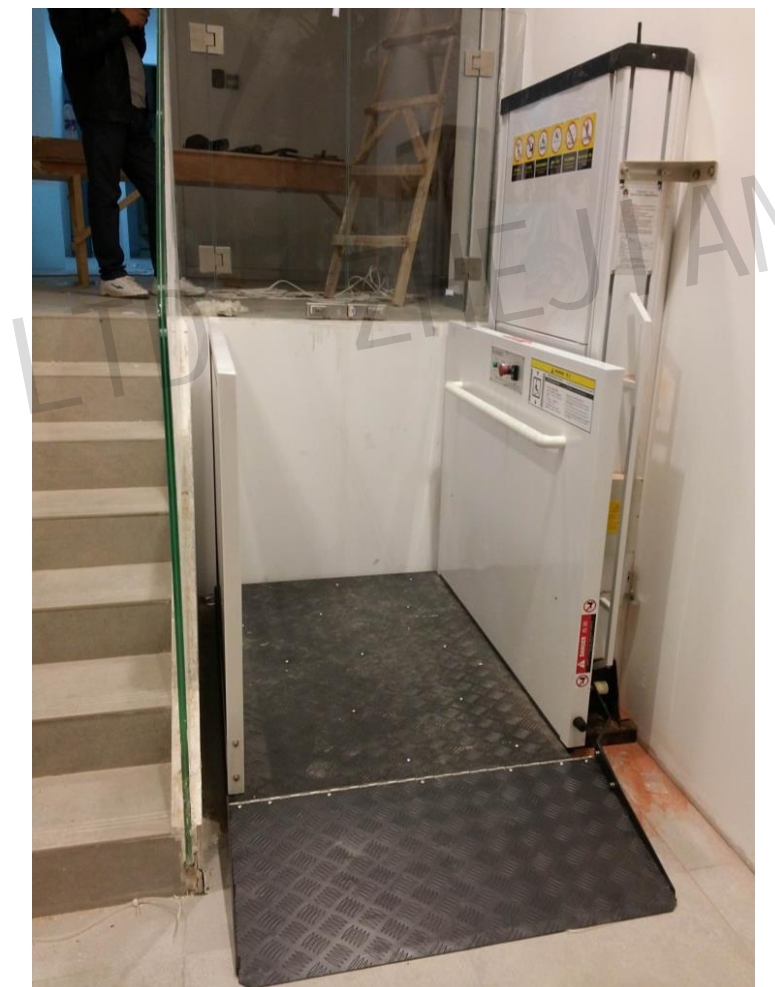



[www.vksfujilift.com](http://www.vksfujilift.com)



ZHEJIANG AOMA ELEVATOR CO., LTD



Add: No. 2555, Qianghua Road, Nanxun Economic Development Zone, Huzhou, Zhejiang, China



+86-0572-3636576



[cyma@vksfujilift.com](mailto:cyma@vksfujilift.com)